



ТОВ «КОМПЛЕКТ ЧПУ»

Номер телефона: 0951719120

Email: komplektcnc@gmail.com

Measurement systems for CNC machine tools



Probing systems for CNC machine tools

| | |
|-----------------------------|-------------|
| Probing Systems..... | 1-1 |
| ELP25N | 1-2 |
| ELP25 | 1-4 |
| EOP40 | 1-6 |
| EOP40-2 | 1-10 |
| ERP40 | 1-14 |
| ERP40-2 | 1-18 |

ELP25N hard-wired probe

Specification

| | | |
|--|---|---------------|
| Principal application | It is used for workpiece detection and workpiece alignment on engraving machine, highlight machine and grinding machine | |
| Transmission type | cable | |
| Cable range | Standard 2 m (line length can be customized) | |
| Cable material | Oil resistant, bending resistant, high flexibility drag chain cable | |
| Recommended styli | Ceramic, lengths 30 mm to 100 mm | |
| Weight without cable support | 160 g | |
| Switch-on method/switch-off methods | Trigger open → No trigger close | |
| Sense directions | ±X,±Y,+Z | |
| Unidirectional repeatability | 1μm 2σ(50 mm styli at a standard test speed of 480 mm/min) | |
| Trigger life | >8million | |
| styli force | XY low force 1 N XY high force 1.5N Z force 5.5 N | |
| Environment | IP rating | IP68 |
| | Storage temperature | -25 °C~+70 °C |
| | Operating temperature | +5 °C~+55 °C |

ELP25N dimensions

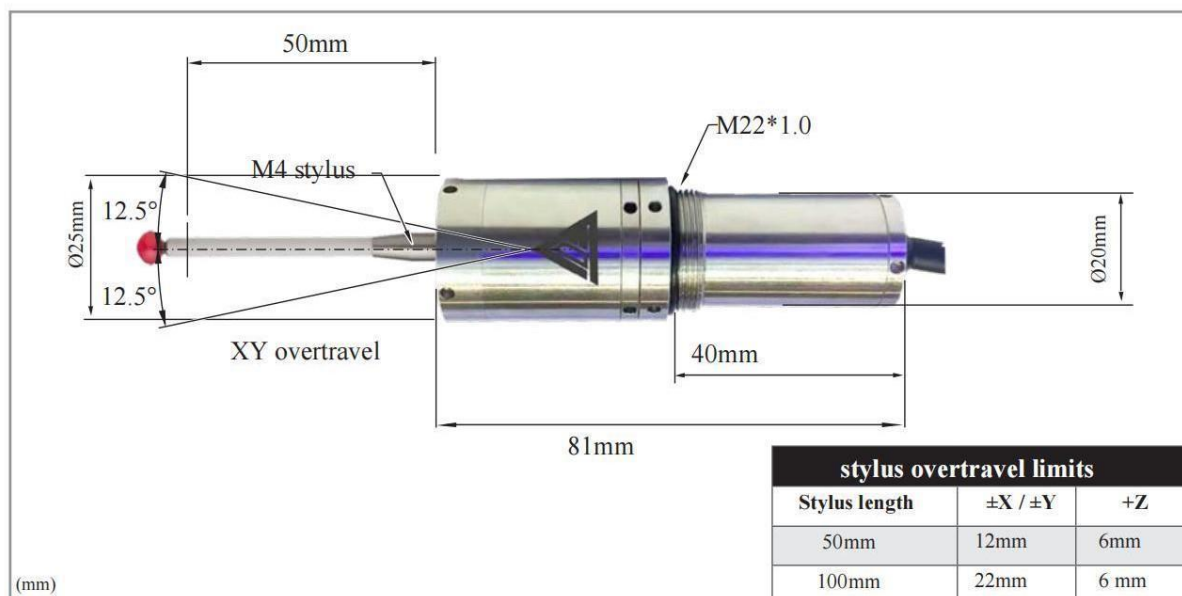

ELP25 hard-wired probe

Specification

| | | |
|--|---|---------------|
| Principal application | It is used for workpiece detection and workpiece alignment on engraving machine, highlight machine and grinding machine | |
| Transmission type | cable | |
| Cable range | Standard 5 m (line length can be customized) | |
| Cable material | Oil resistant, bending resistant, high flexibility drag chain cable | |
| Recommended styli | Ceramic, lengths 30 mm to 100 mm | |
| Weight without cable support | 80 g | |
| Switch-on method/switch-off methods | Trigger open → No trigger close | |
| Sense directions | ±X,±Y,+Z | |
| Unidirectional repeatability | 0.5 μm 2σ(50 mm styli at a standard test speed of 480 mm/min) | |
| Trigger life | >10 million | |
| styli force | XY low force 0.6 N XY high force 1.2 N Z force 4.5 N | |
| Environment | IP rating | IP68 |
| | Storage temperature | -25 °C~+70 °C |
| | Operating temperature | +5 °C~+55 °C |

ELP25 dimensions

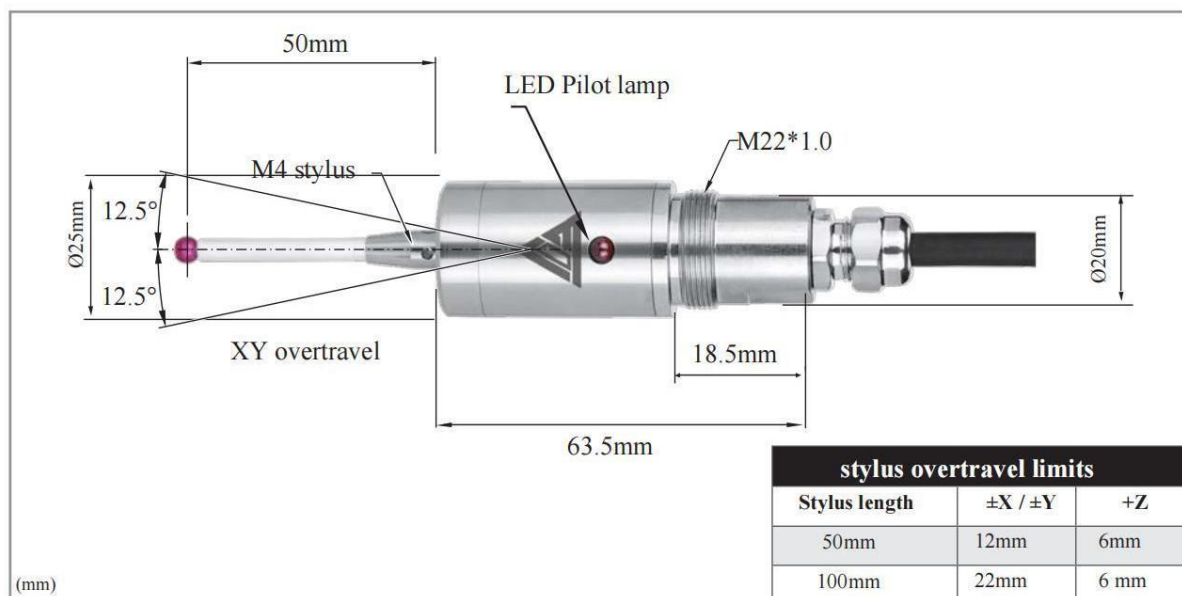

EOP40 Optical machine tool probe

Specification

| | | | |
|--|-----------------------|---|---------------|
| Principal application | | Used for workpiece inspection and alignment on machining centers and lathes, composite machine tools. | |
| Transmission type | | 360° infrared optical transmission | |
| Operating range | | Up to 5 m | |
| Recommended styli | | Ceramic, lengths 50 mm to 150 mm | |
| Weight without shank | | 280g | |
| Switch-on method/switch-off methods | | Trigger open → No trigger close (no need for M code control) | |
| Battery life 2 X 3.6 V L14250 (Brand: SAFT) | Standby life | 3 year | |
| | Continuous use | 4000 hours maximum, Depends on the number of triggers | |
| Sense directions | | ±X, ±Y, +Z | |
| Unidirectional repeatability | | 1.00µm 2σ(50 mm styli at a standard test speed of 480 mm/min) | |
| Trigger life | | >10 million | |
| styli force | | | |
| XY low force | | 0.45 N | |
| XY high force | | 0.85 N | |
| Z force | | 5.75 N | |
| Environment | | IP rating | IP68 |
| | | Storage temperature | -25 °C~+70 °C |
| | | Operating temperature | +5 °C~+55 °C |

EOP40 dimensions

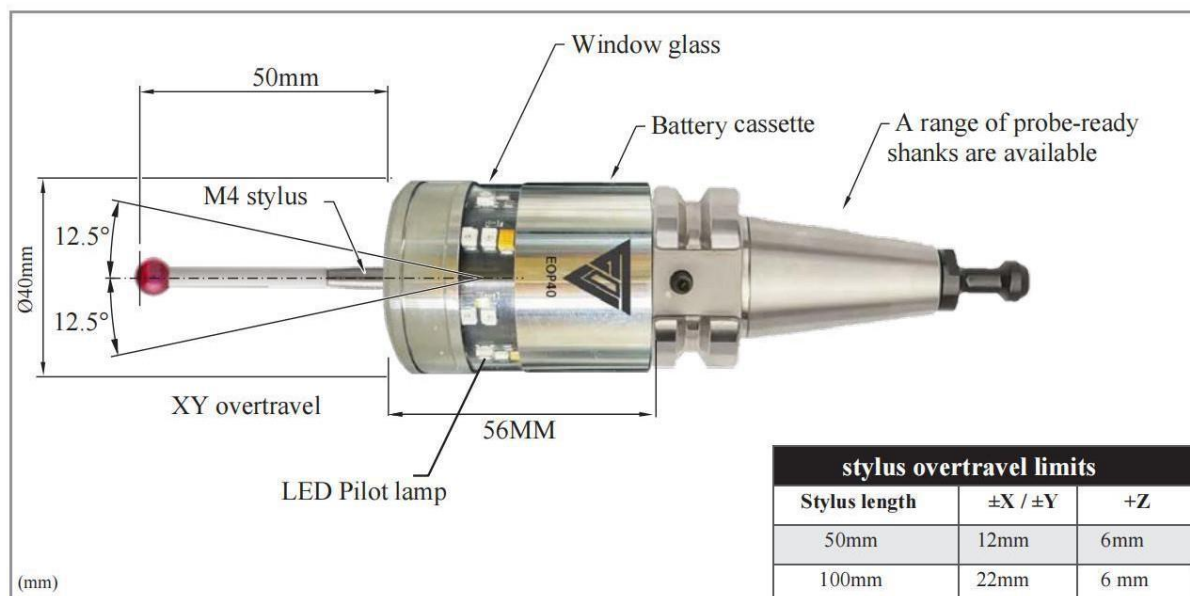

EOP40 and EOI40 signal transmission

The EOP40 optical probe has a 360° transmission range, as shown below. The probe system should be positioned during installation so that it can achieve the best signal transmission over the entire shaft travel range of the machine.

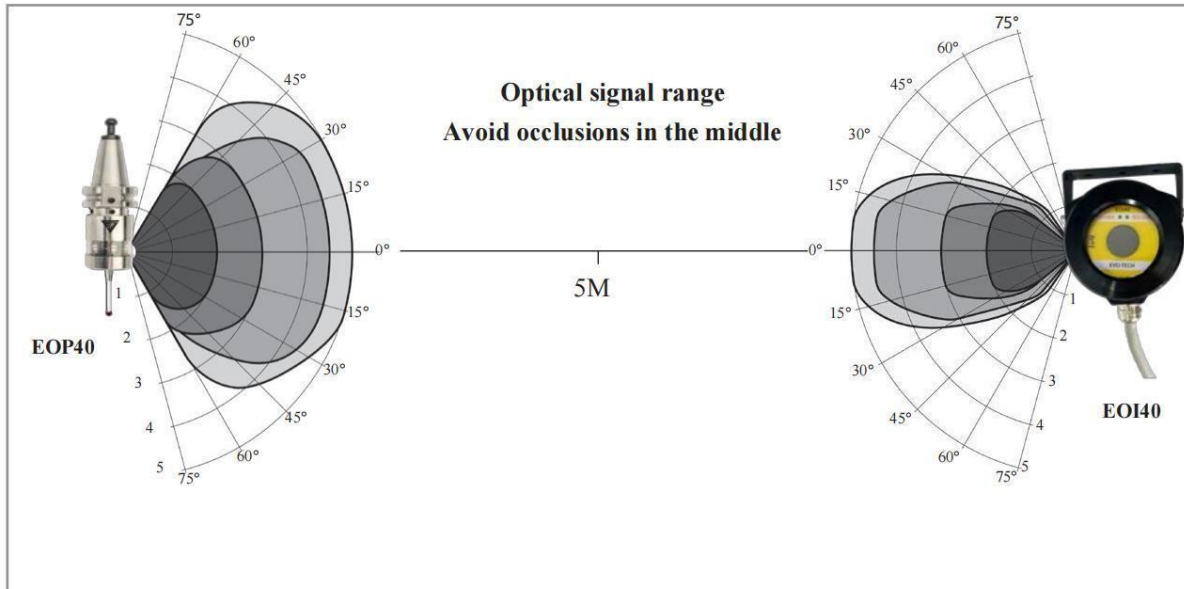

The products of optical transmission of products, they do not need to match, can be exchanged.

❖ Warning:

The natural reflective surface on the machine may affect the signal transmission range.

Coolant residue that accumulates on the receiver can adversely affect transmission performance. It should be wiped frequently to ensure that the signal transmission is not affected in any way.

EOP40-2 Optical machine tool probe

Specification

| | | |
|---|-----------------------|---|
| Principal application | | Used for workpiece inspection and alignment on machining centers and lathes, composite machine tools. |
| Transmission type | | 360° infrared optical transmission |
| Operating range | | Up to 5 m |
| Recommended styli | | Ceramic, lengths 50 mm to 150 mm |
| Weight without shank | | 250g |
| Switch-on method/switch-off methods | | Optical open → Optical off (need for M code control) |
| Battery life 2 X 3.6 V L14250(Brand: SAFT) | Standby life | Standby life: 1500 days maximum, dependent on switch-on/switch-off option |
| | Continuous use | Continuous use: 2000 hours maximum, dependent on switch-on/switch-off option |
| Sense directions | | ±X, ±Y, +Z |
| Unidirectional repeatability | | 1.00µm 2σ(50 mm styli at a standard test speed of 480 mm/min) |
| Trigger life | | > 10 million |
| styli force | | |
| XY low force | | 0.45 N |
| XY high force | | 0.85 N |
| Z force | | 5.75 N |
| Environment | IP rating | IP68 |
| | Storage temperature | -25 °C~+70 °C |
| | Operating temperature | +5 °C~+55 °C |

EOP40-2 dimensions

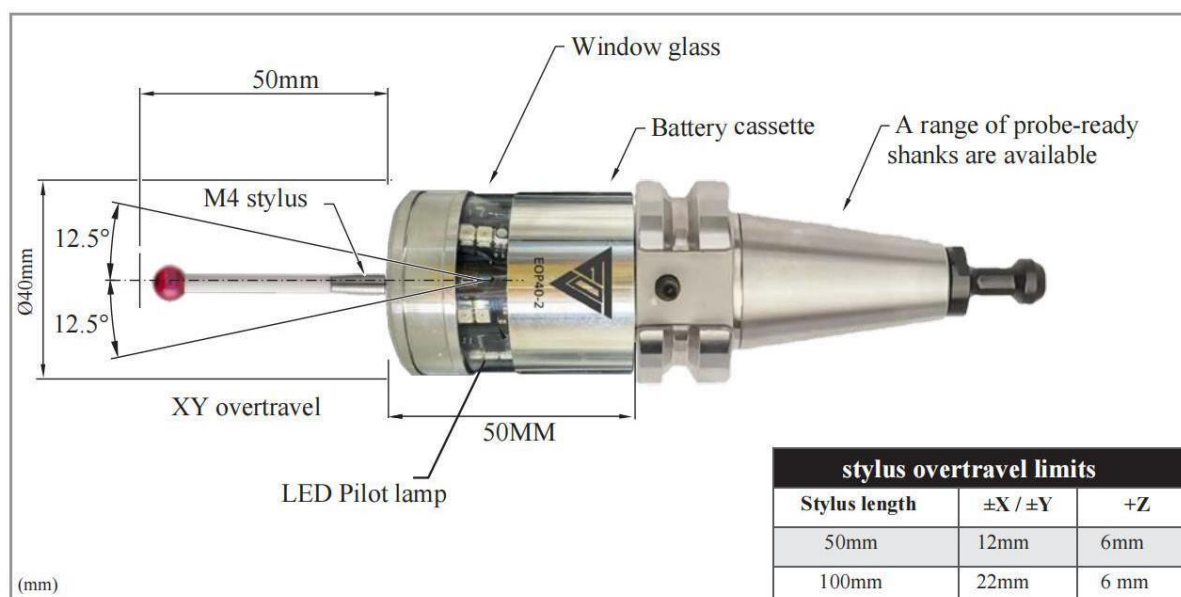

EOP40-2 and EOI40-2 signal transmission

The EOP40-2 optical probe has a 360° transmission range, as shown below. The probe system should be positioned during installation so that it can achieve the best signal transmission over the entire shaft travel range of the machine.

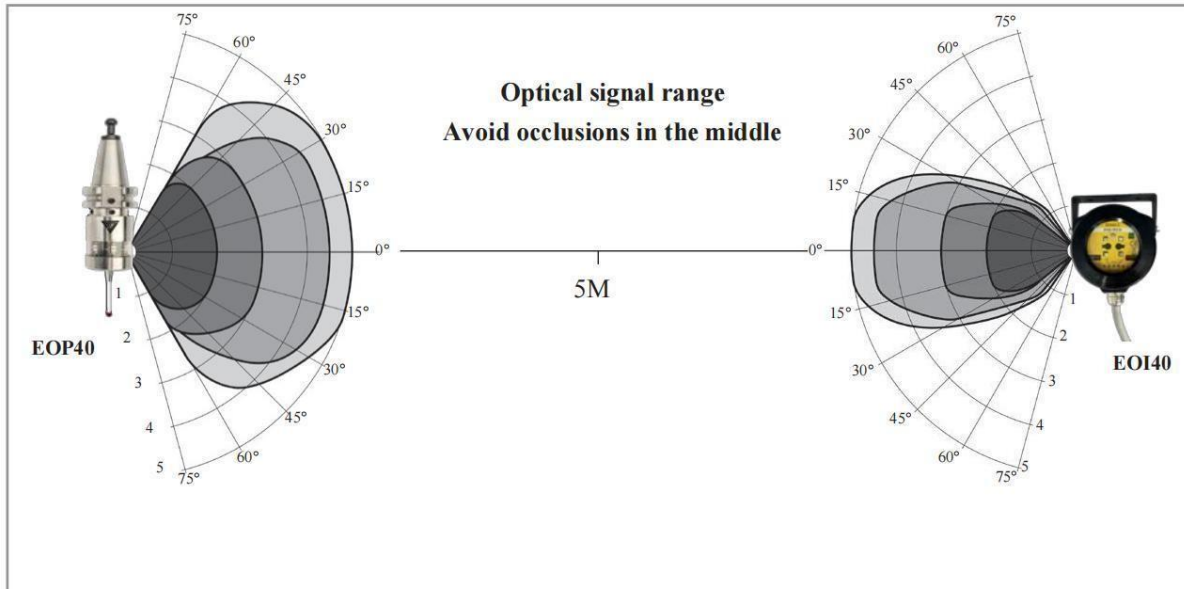

The products of optical transmission of products, they do not need to match, can be exchanged.

❖ Warning:

The natural reflective surface on the machine may affect the signal transmission range.

Coolant residue that accumulates on the receiver can adversely affect transmission performance. It should be wiped frequently to ensure that the signal transmission is not affected in any way.

ERP40 Radio machine tool probe

Specification

| | | | |
|--|-----------------------|---|---------------|
| Principal application | | Used for workpiece inspection and alignment on machining centers and lathes, composite machine tools. | |
| Transmission type | | 360° infrared radio transmission | |
| Operating range | | Up to 10 m | |
| Recommended styli | | Ceramic, lengths 50 mm to 150 mm | |
| Weight without shank | | 280g | |
| Switch-on method/switch-off methods | | Trigger open → No trigger close (no need for M code control) | |
| Battery life 2 X 3.6 V L14250 (Brand: SAFT) | Standby life | 3 year | |
| | Continuous use | 4000 hours maximum, Depends on the number of triggers | |
| Sense directions | | ±X, ±Y, +Z | |
| Unidirectional repeatability | | 1.00µm 2σ(50 mm styli at a standard test speed of 480 mm/min) | |
| Trigger life | | >10 million | |
| styli force | | | |
| XY low force | | 0.45 N | |
| XY high force | | 0.85 N | |
| Z force | | 5.75 N | |
| Environment | | IP rating | IP68 |
| | | Storage temperature | -25 °C~+70 °C |
| | | Operating temperature | +5 °C~+55 °C |

ERP40 dimensions

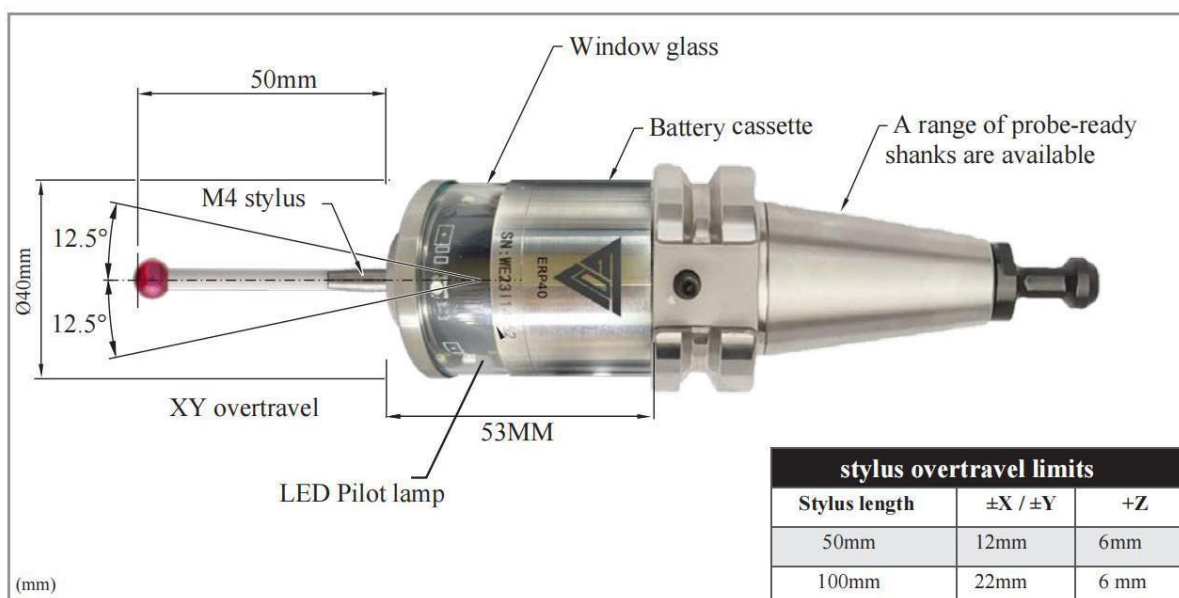

ERP40 and ERI40 Signal transmission

The ERP40 radio probe has a 360° transmission range, as shown below. The probe system should be positioned during installation so that it can achieve the best signal transmission over the entire shaft travel range of the machine.

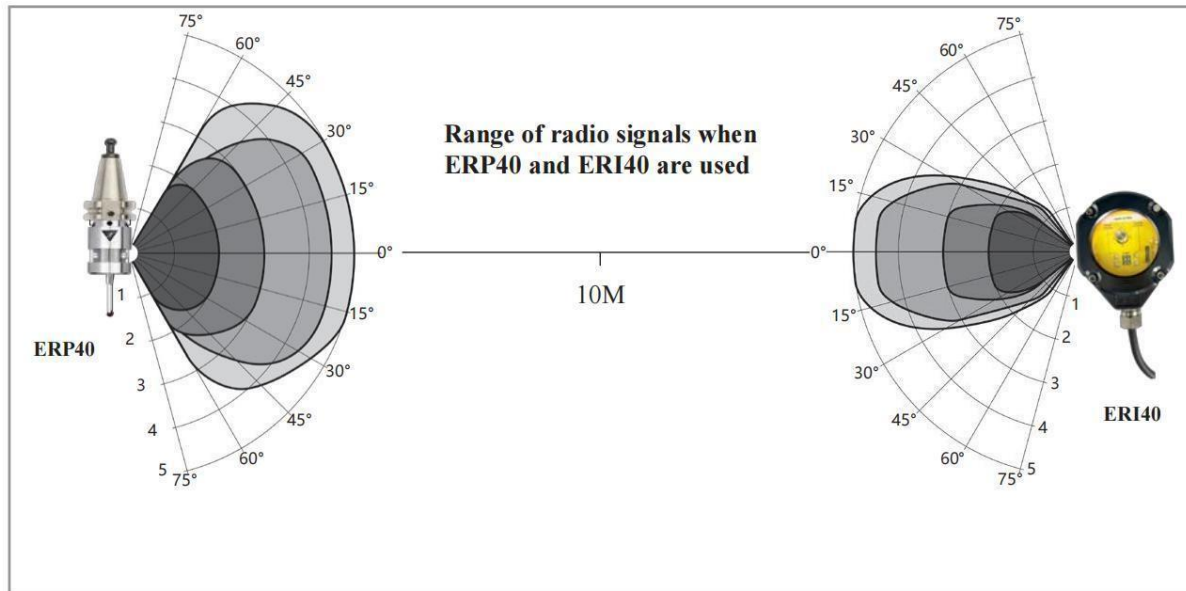

The products of radio transmission and optical transmission are different, and they need to be matched, which we will set up in the factory.

ERP40-2 Raido machine tool probe

Specification

| | | | |
|--|-----------------------|---|---------------|
| Principal application | | Used for workpiece inspection and alignment on machining centers and lathes, composite machine tools. | |
| Transmission type | | 360° infrared radio transmission | |
| Operating range | | Up to 15 m | |
| Recommended styli | | Ceramic, lengths 50 mm to 150 mm | |
| Weight without shank | | 280g | |
| Switch-on method/switch-off methods | | Radio open → Radio close (need for M code control) | |
| Battery life 2 X 3.6 V L14250 (Brand: SAFT) | Standby life | Standby life: 1500 days maximum, dependent on switch-on/switch-off option | |
| | Continuous use | Continuous use: 2000 hours maximum, dependent on switch-on/switch-off option | |
| Sense directions | | ±X, ±Y, +Z | |
| Unidirectional repeatability | | 1.00µm 2σ(50 mm styli at a standard test speed of 480 mm/min) | |
| Trigger life | | >10 million | |
| styli force | | | |
| XY low force | | 0.45 N | |
| XY high force | | 0.85 N | |
| Z force | | 5.75 N | |
| Environment | | IP rating | IP68 |
| | | Storage temperature | -25 °C~+70 °C |
| | | Operating temperature | +5 °C~+55 °C |

ERP40-2 dimensions

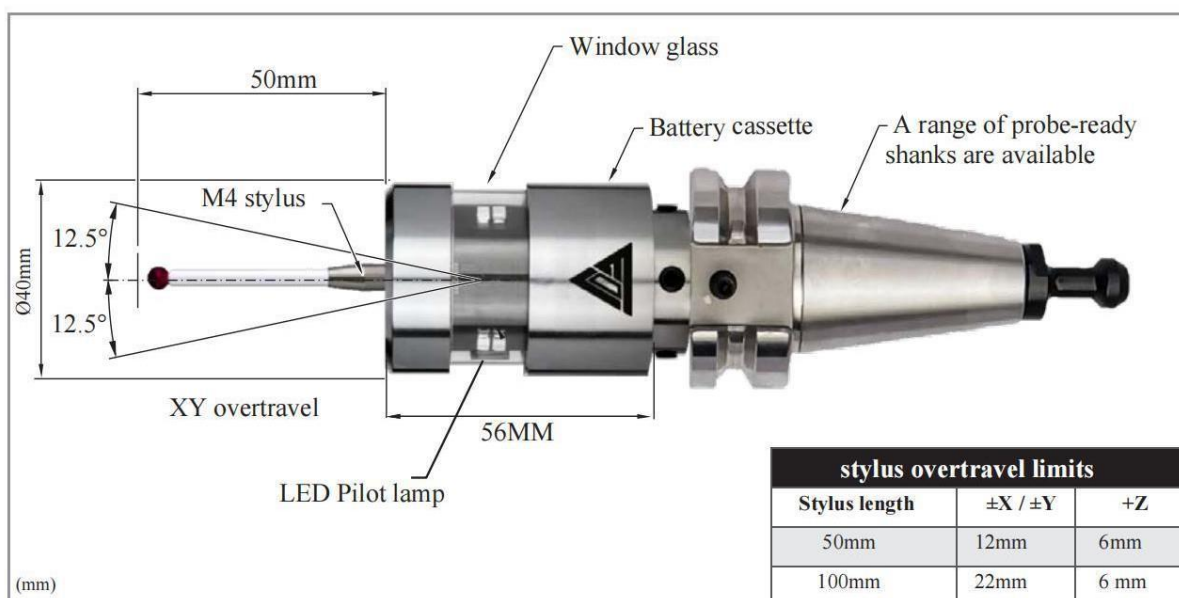

ERP40-2 and ERI40-2 Signal transmission

The ERP40-2 radio probe has a 360° transmission range, as shown below. The probe system should be positioned during installation so that it can achieve the best signal transmission over the entire shaft travel range of the machine.

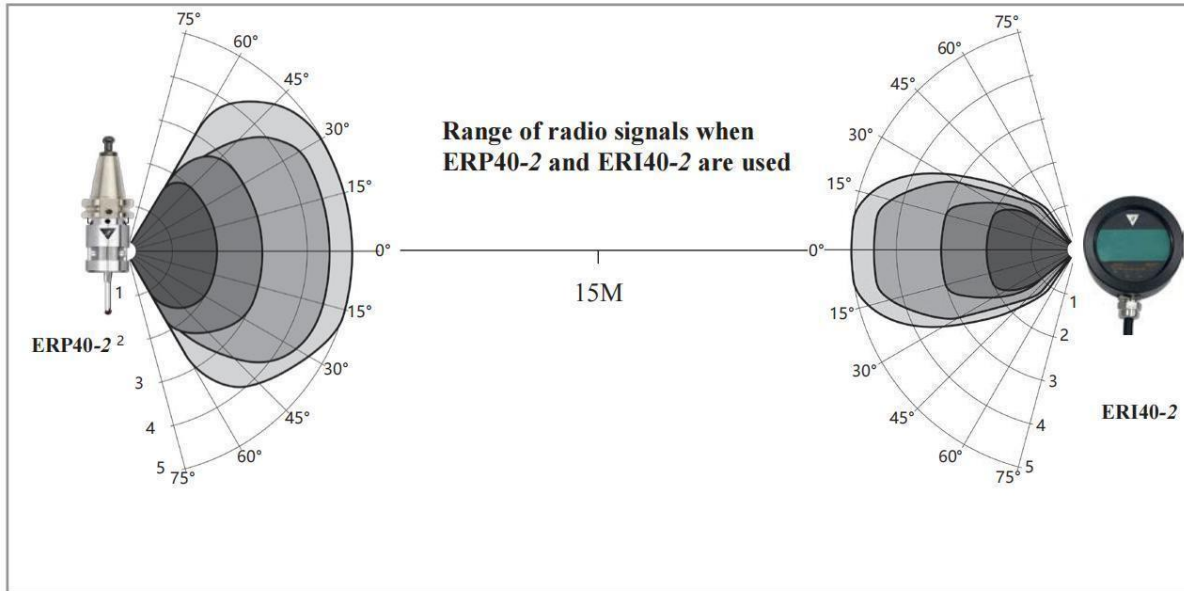

The products of radio transmission and optical transmission are different, and they need to be matched, which we will set up in the factory.

Tool setting systems for CNC machine tools

| | |
|-----------------------------------|------------|
| Tool setting Systems | 2-1 |
| ETMP21W | 2-2 |
| ETM26D-20W | 2-3 |
| ETM26D-20A | 2-4 |
| ETM26D-20S | 2-5 |
| 5-ETM | 2-6 |
| 5-ETM27R | 2-7 |
| 5-EOTM | 2-8 |
| 5-ERTM | 2-9 |

Tool Setters for Small Machining Centers and Milling Machines

ETMP21W



with overtravel (OT) signal

- Used for CNC glass machine, dispensing machine tool measurement, wear, damage detection.
- Alarm signal will occur when exceeding the travel, which can prevent damage accidents



Replaceable p21

■ Specification

| | |
|--|--|
| Product Name | ETMP21W |
| Contact diameter | Φ10mm |
| Contact surface | grind |
| Contact material | Superhard alloy |
| Action mode Output mode Pretravel | NC |
| Stroke Repeatability | 0.5mm |
| Contact life time | 5mm |
| Protective Contact | 0.002mm (operating speed of 50-200mm/min) |
| Force Contact rating | >5 million |
| Protective | IP67 |
| Contact Force | 1.5N(Installation status: Vertical) |
| Contact rating | DC5V to DC24V Steady state current less than 10mA Inrush current below 20mA |
| Cable | 5m Oil resistance ·6 core Φ3.7MM, Tensile strength 30N, bending radius R7 |
| Protective pipe | 1.5m metal Minimum bending radius R25 |
| LED indicator | 6 cores with LED,4 core without LED |
| Over travel signal | NC [About 2.5mm from the detection signal] |
| Contact rating | DC24V 100mA |

■ Circuit Diagram

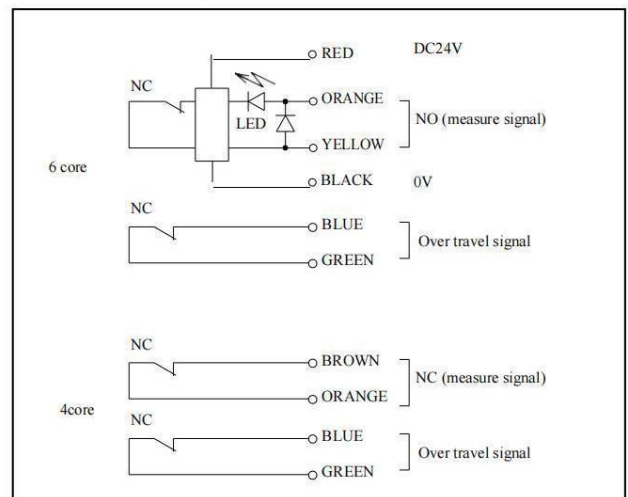

■ Warning

- When high-pressure coolant or water jet violently impacts the tool face or sleeve protective cover, please set a separate protective cover
- Coolant used, set to water-soluble coolant (alkaline)
- The feed speed should not be less than 10mm/min when used

Tool Setter Series for Woodworking machinery

ETM26D-20W

Φ20 contact surface

- Used for Woodworking machinery tool measurement, wear, damage detection
- With overstroke alarm signal



■ Specification

| | |
|---------------------------|--|
| Product Name | ETM26D-20W |
| Contact diameter | Φ20mm |
| Contact surface | grind |
| Contact material | Superhard alloy |
| Action mode | NC |
| Output mode | NC |
| Pretravel | 0. mm |
| Stroke | 8mm |
| Repeatability | 0.002mm (operating speed of 50-200mm/min) |
| Contact life time | >5 million |
| Protective | IP65 |
| Contact Force | 1.3N (Installation status: Vertical) |
| Contact rating | DC5V to DC24V Steady state current less than 10mA Inrush current below 20mA |
| Cable | 2m Oil resistance ·4core |
| Protective pipe | 0.5m metal |
| Over travel signal | NC [About 2.5mm from the detection signal] |
| Contact rating | DC24V 100mA |

■ Circuit Diagram

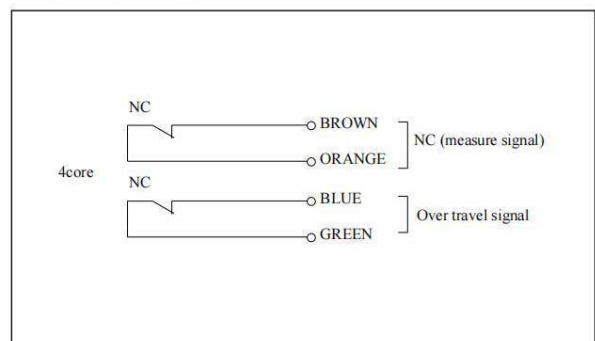

■ Warning

- When high-pressure coolant or water jet violently impacts the tool face or sleeve protective cover, please set a separate protective cover
- The feed speed should not be less than 10mm/min when used

Tool Setter Series for CNC Machining Centers

ETM26D-20A

Φ20 contact surface

- Used for CNC machine tool measurement, wear, damage detection
- With overstroke alarm signal
- Made of aircraft grade aluminum



Replaceable TM26D

■ Specification

| | |
|---------------------------|--|
| Product Name | ETM26D-20A |
| Contact diameter | Φ20mm |
| Contact surface | grind |
| Contact material | Superhard alloy |
| Action mode | NC |
| Output | NO |
| Pretravel | 0.5mm |
| Stroke | 5mm |
| Repeatability | 0.002mm (operating speed of 50-200mm/min) |
| Contact life time | >5million |
| Protective | IP68 |
| Contact Force | 1.5N (Installation status: Vertical) |
| Contact rating | DC5V to DC24V Steady state current less than 10mA Inrush current below 20mA |
| Cable | 5m Oil resistance ·6 core/4core |
| Protective pipe | 1.5m metal Minimum bending radius R25 |
| LED indicator | Turn off normally and light up when measuring |
| Over travel signal | NC [About 2.5mm from the detection signal] |
| Contact rating | DC24V 100mA |

■ Circuit Diagram

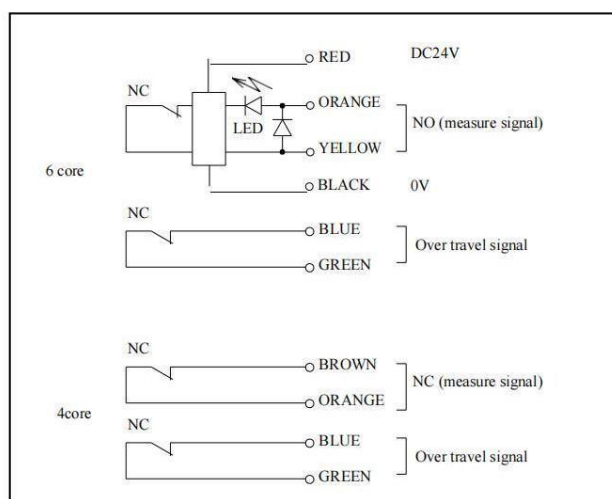

■ Warning

- When high-pressure coolant or water jet violently impacts the tool face or sleeve protective cover, please set a separate protective cover
- Coolant used, set to water-soluble coolant (alkaline)
- The feed speed should not be less than 10mm/min when used

Tool Setter Series for CNC Machining Centers

ETM26D-20S

Φ20 contact surface

- Used for CNC machine tool measurement, wear, damage detection
- With overstroke alarm signal
- 304 stainless steel



Replaceable TM26D

■ Specification

| | |
|---------------------------|--|
| Product Name | ETM26D-20S |
| Contact diameter | Φ20mm |
| Contact surface | grind |
| Contact material | Superhard alloy |
| Action mode | NC |
| Output | NO |
| Pretravel | 0.5mm |
| Stroke | 5mm |
| Repeatability | 0.002mm (operating speed of 50-200mm/min) |
| Contact life time | >8million |
| Protective | IP68 |
| Contact Force | 1.5N (Installation status: Vertical) |
| Contact rating | DC5V to DC24V Steady state current less than 10mA Inrush current below 20mA |
| Cable | 5m Oil resistance ·6 core/4core |
| Protective pipe | 1.5m metal Minimum bending radius R25 |
| LED indicator | Turn off normally and light up when measuring |
| Over travel signal | NC [About 2.5mm from the detection signal] |
| Contact rating | DC24V 100mA |

■ Circuit Diagram

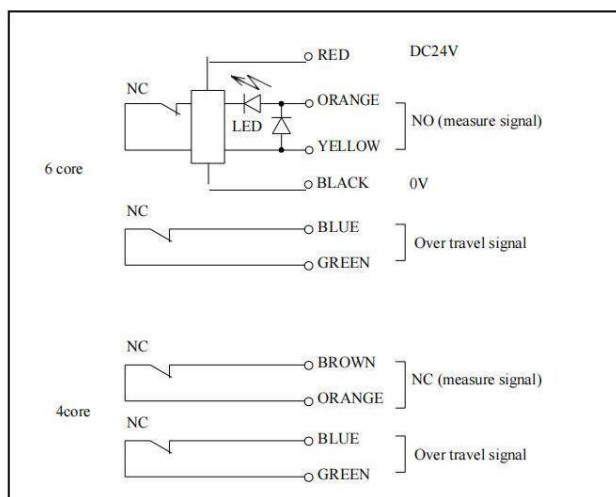

■ Warning

- When high-pressure coolant or water jet violently impacts the tool face or sleeve protective cover, please set a separate protective cover
- Coolant used, set to water-soluble coolant (alkaline)
- The feed speed should not be less than 10mm/min when used

Contact tool sets for measuring tool lengths and diameters

5-ETM27R

Φ12.7contact surface



■ Can cope with drilling, end milling cutter, and other types of tools.

■ 70% space saving

Small design construction, can also be installed in narrow Spaces.



replacement for TS27R

■ Specification

| | |
|--------------------------|--|
| Product Name | 5-ETM27R |
| Contact diameter | Φ12.7×10mm |
| Contact material | Superhard alloy |
| Action mode | NC |
| Output mode | NO |
| Pretravel | 0mm |
| Trigger travel | +X=2.0 -X=1.0 ±Y=2.0 Z=1.9 |
| Repeatability | 0.002 (2σ) (Operating speed 50 ~ 200mm/min) |
| Contact life time | > 5 million |
| Protective | IP67 |
| Contact Force | X=1.0N Y=1.5N Z=1.0N |
| Contact rating | DC5V to DC24V Steady state current less than 10mA Inrush current below 20mA |
| Cable | 5m Oil resistance ·4 core |
| Protective pipe | 1.5m plastic protective tube |
| LED indicator | no |

■ Circuit Diagram

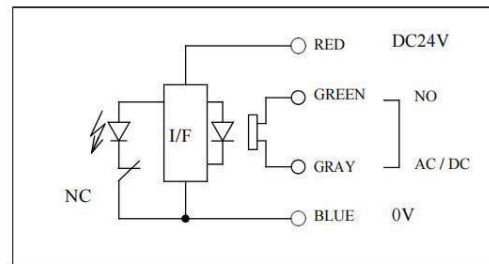

■ Warning

- When high-pressure coolant or water jet violently impacts the tool face or sleeve protective cover, please set a separate protective cover
- Coolant used, set to water-soluble coolant (alkaline)
- Clean the tool and tool setting surface before inspection

Contact tool sets for measuring tool lengths and diameters

5-ETM

Φ12.7contact surface



■ Can cope with drilling, end milling cutter, and other types of tools.

■ 70% space saving

Small design construction, can also be installed in narrow Spaces.



replacement for TS27R

■ Specification

| | |
|--------------------------|--|
| Product Name | 5-ETM |
| Contact diameter | Φ12.7×10mm |
| Contact material | Superhard alloy |
| Action mode | NC |
| Output mode | NO |
| Pretravel | 0mm |
| Trigger travel | +X=2.0 -X=1.0 ±Y=2.0 Z=1.9 |
| Repeatability | 0.001 (2σ) (Operating speed 50 ~ 200mm/min) |
| Contact life time | > 10 million |
| Protective | IP68 |
| Contact Force | X=1.5N Y=2.0N Z=1.5N |
| Contact rating | DC5V to DC24V Steady state current less than 10mA Inrush current below 20mA |
| Cable | 5m Oil resistance ·6 core Φ6.2MM, Tensile strength 30N, bending radius R7 |
| Protective pipe | 1.5m metal Minimum bending radius R25 |
| LED indicator | Turn off normally and light up when measuring |

■ Circuit Diagram

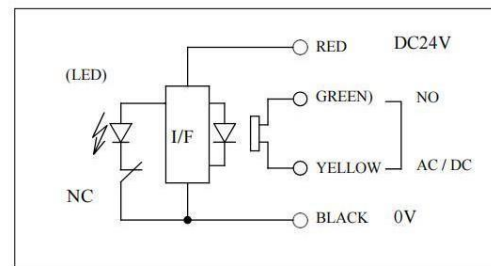

■ Warning

- When high-pressure coolant or water jet violently impacts the tool face or sleeve protective cover, please set a separate protective cover
- Coolant used, set to water-soluble coolant (alkaline)

Optical Contact tool sets for measuring tool lengths and diameters

5-EOTM

Φ12.7contact surface



- Can cope with drilling, end milling cutter, and other types of tools.
- 70% space saving
Small design construction, can also be installed in narrow Spaces.



replacement for OTS

■ Specification

| | | |
|---|--|---|
| Product Name | 5-EOTM | |
| Contact diameter | Φ12.7×10mm | |
| Contact material | Superhard alloy | |
| Action mode | NC | |
| Output mode | NO | |
| Pretravel | 0mm | |
| Trigger travel | +X=2.0 -X=1.0 ±Y=2.0 Z=1.9 | |
| Repeatability | 0.001 (2σ) (Operating speed 50 ~ 200mm/min) | |
| Contact life time | > 10 million | |
| Protective | IP68 | |
| Contact Force | X=1.5N Y=2.0N Z=1.5N | |
| Battery life 2 x 3.6 V L14250(Brand: SAFT) | Standby life | 3 year |
| | Continuous use | 4000 hours maximum, Depends on the number of triggers |
| LED indicator | Turn off normally and light up when measuring | |

■ Circuit Diagram

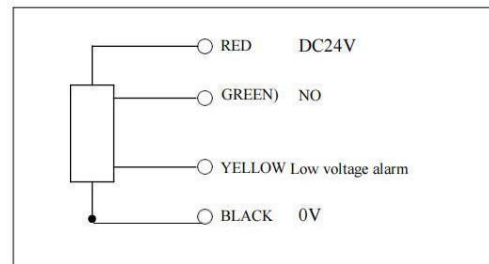

■ Warning

- When high-pressure coolant or water jet violently impacts the tool face or sleeve protective cover, please set a separate protective cover
- Coolant used, set to water-soluble coolant (alkaline)
- Coolant residue that accumulates on the receiver can adversely affect transmission performance. It should be wiped frequently to ensure that the signal transmission is not affected in any way.

Radio Contact tool sets for measuring tool lengths and diameters

5-ERTM

Φ12.7contact surface



- Can cope with drilling, end milling cutter, and other types of tools.
- 70% space saving
Small design construction, can also be installed in narrow Spaces.



replacement for RTS

■ Specification

| | | |
|---|--|---|
| Product Name | 5-ERTM | |
| Contact diameter | Φ12.7×10mm | |
| Contact material | Superhard alloy | |
| Action mode | NC | |
| Output mode | NO | |
| Pretravel | 0mm | |
| Trigger travel | +X=2.0 -X=1.0 ±Y=2.0 Z=1.9 | |
| Repeatability | 0.001 (2σ) (Operating speed 50 ~ 200mm/min) | |
| Contact life time | > 10 million | |
| Protective | IP68 | |
| Contact Force | X=1.5N Y=2.0N Z=1.5N | |
| Battery life 2 x 3.6 V L14250(Brand: SAFT) | Standby life | 3 year |
| | Continuous use | 4000 hours maximum, Depends on the number of triggers |
| LED indicator | Turn off normally and light up when measuring | |

■ Circuit Diagram

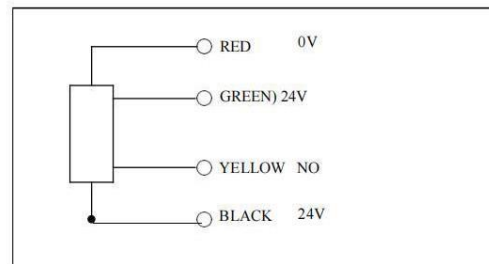

■ Warning

- When high-pressure coolant or water jet violently impacts the tool face or sleeve protective cover, please set a separate protective cover
- Coolant used, set to water-soluble coolant (alkaline)