

Installation

FSCUT3000DE-H User Manual

Shanghai Friendess Co., Ltd

www.fscut.com

Ver 1.1



Table of Contents

Table of Contents	2
Chapter I Overview	4
1.1 Introduction	4
1.2 System Diagram	4
1.3 Product Details	5
Chapter II Wiring Instruction	6
2.1 BMC2283 Installation	6
2.1.1 Dimension Diagram	7
2.1.2 Installation Diagram	7
2.1.3 Ethernet Terminal	9
2.1.4 PCIE Socket	10
2.2 BCL4566E Wiring	11
2.2.1 Interface Layout	12
2.2.2 J01 Power Supply	12
2.2.3 J02 PWM/DA Terminals	13
2.2.4 J03/J04/J05 Output Terminal	14
2.2.5 J06/J07/J08 Input Terminal	14
2.2.6 J09/J10 Network	16
2.2.7 J11 Sensor	16
2.2.8 J12DB15 Servo Axis Interface	16
2.3 Cutter Wiring	20
2.3.1 ProCutter Wiring	20
2.4 Laser Wiring	21
2.4.1 IPG_YLS Germany	21
2.4.2 IPG American	22
2.4.3 RayCus	23
2.4.4 Trumpf	24
Chapter III Installation	25
3.1 Installation Steps	25
3.1.1 Step 1. Install BMC2283 Control Card	25
3.1.2 Step 2. Install BMC2283 Driver	25
3.1.3 Step 3. Connect Slave	26
3.1.4 Step 4. Scan in Machine Config Tool	26
3.1.5 Step 5 Use TubePro	26
Chapter IV Precautions	27
4.1 Wiring Precautions	27
4.1.1 Drag Chain Wiring	27
4.1.2 Machine Tool Wiring	29
4.1.3 Assembly Requirements	31
4.2 Troubleshooting	31



4.2.1	Device Manager cannot find PCIe devices	31
4.2.2	Device Manager cannot install driver	32
4.2.3	Bus Scan failed	32
4.2.4	Bus network alarm	33



Chapter I Overview

1.1 Introduction

FSCUT3000DE-H is a cost-effective CNC system for tube laser cutting. It is based on EtherCAT bus technology and capable of motion control, laser control, and cutting gas control. It is common used in sanitary ware, kitchen ware, hardware, gym equipment and such industries. This user manual is only for installation guidance.

1.2 System Diagram

FSCUT3000DE-H includes the bus BMC2283 Control Card, the bus IO board, and the bus height controller, among which the BMC2283 control card integrates the EtherCAT master protocol stack.

The network cable is led out from the network port of BMC2283 and connected to the BLT cutting head. The wiring diagram is shown as below.

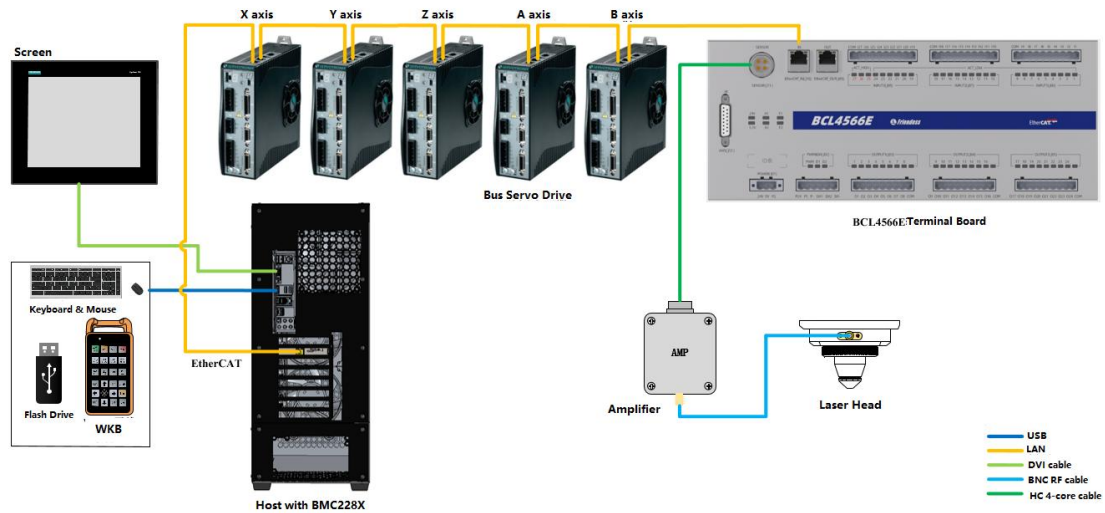

Figure Wiring diagram of FSCUT3000DE-H



1.3 Product Details

FSCUT3000DE-H bus CNC system includes BMC2283 Control Card, BCL4566E terminal board, WKB V6, and related cables.

<p>BMC2283 Control Card (1)</p>	<p>WKB V6 (1)</p>	<p>BCL4566E Terminal Board (1)</p>
		
<p>SPC RF cable (2)</p>	<p>Amplifier (1)</p>	<p>HC four-core cable (1)</p>
		
<p>LAN Cables (3000DE-H) LAN-0 3X(4) LAN-1X (1) LAN-3X (1)</p>		
		

Table 1- 1 FSCUT3000DE-H specifications



Chapter II Wiring Instruction

2.1 BMC2283 Installation

BMC2283 Control Card is a motion control card based on the EtherCAT Its 1.0Ghz main chip provides excellent overall performance and has passed Friendess stringent testing standards.

<p style="text-align: center;">BMC2283 EtherCAT Control Card</p>	
Bus Protocol	EtherCAT Master Protocol
PCI Express	PCI Express2.0 (Gen2)
Power Supply	Powered by PCIe motherboard, max 12V/1A, no hot plug
Anti-interference Level	ESD 3 (6kV contact, 8kV air), EFT 4 (4kV power supply, 2kV signal), Surge international 2 (2kV AC line, 1kV DC line)
Dimension and Weight	
Dimension	(L x W x H) 127.6mm x121.0mm x21.45mm
Weight	80g
Features	
Cooling	Nature Cooling
Operating Environment Temperature	0~+60°C
Storage temperature	-20~+70°C
Humidity	0% to 90% (non-condensation)
Certification	CE
Installation Environment Requirement	
<p>The waterproof and dustproof grade of the Control Card is IP00, unprotected. Please place the computer in a clean, dust-free environment.</p>	

Table 2-1 BMX2283 Technical Data



2.1.1 Dimension Diagram

BMC2283 Control Card dimension (mm) is shown in Figure 3.

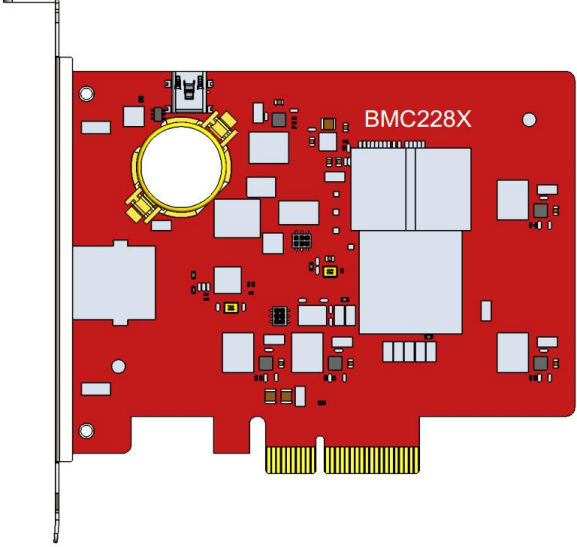
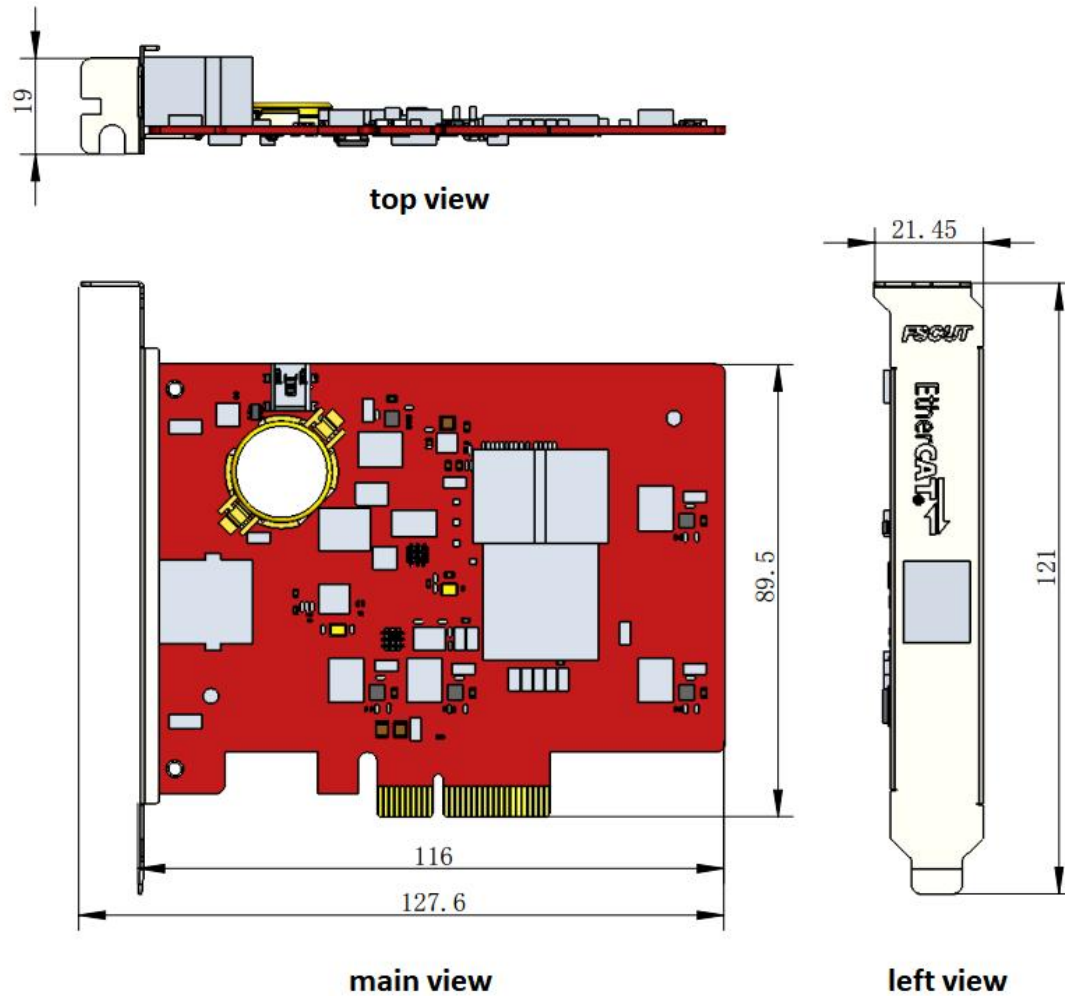

Figure 3 BMC2283 Dimension

2.1.2 Installation Diagram

Install BMC2283 in the socket of PCIE X4 and up with even force (refer to ②), secure its blank screw (refer to ①). Be aware of the heat dissipation for BMC228X and keep it away from other cards as far away as possible. Refer to the diagram below.

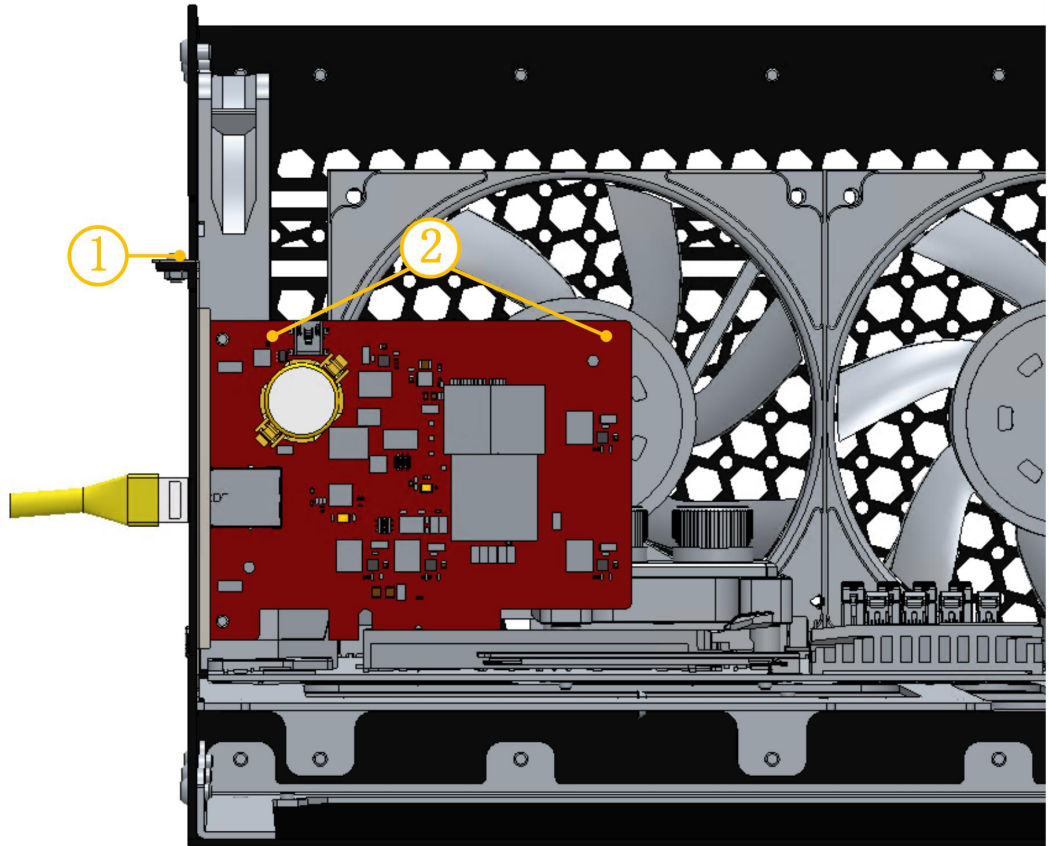

Figure BMC2283 Control Card Installation

BMC228X installed is shown below.

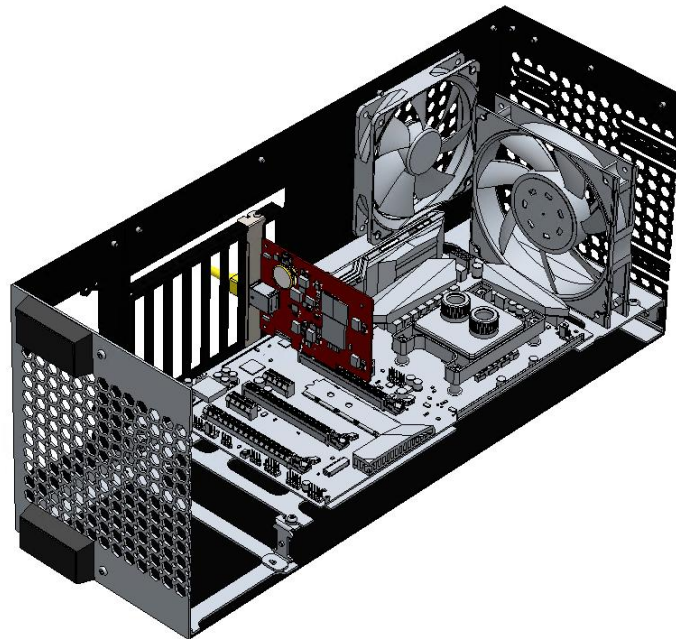
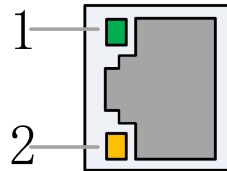

Figure BMC2283 Control Card Installed



2.1.3 Ethernet Terminal

The standard socket of BMC2283 is RJ45 that can be used to connect EtherCAT slave devices(servo drives, BCS100E, HPL2720E, etc.)



Label	Description	LED Color	Status	Description
1: Speed	Ethernet communication connection speed	Green	Off	10 Mbps connection
			Solid	100 Mbps connection
2: Link	Ethernet communication link status	Yellow	Off	No connection
			Flashes	Communicating
			Solid	Connected

Table 2-2 Description of RJ45 connection status



2.1.4 PCIE Socket

BMC2283 PCIE socket is X4 (Figure 6①)and can be used for X4, X8, X16. Its PCI Express Protocol standard is V2.0 (Gen2) and the BMC2283 motherboard requirements are as shown in Table 2-3.

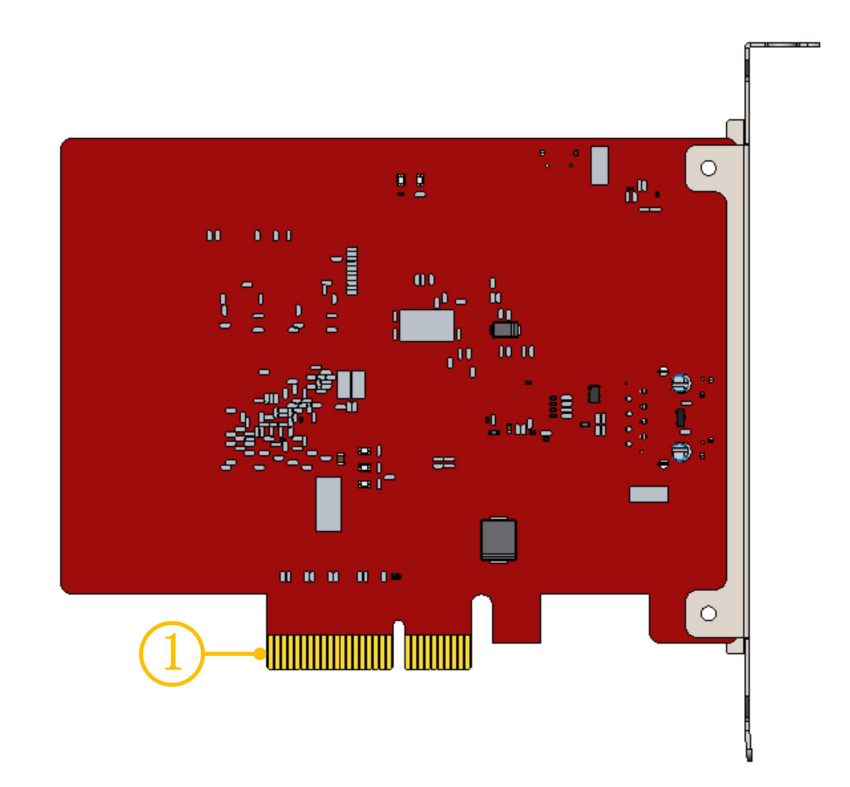

Figure Gold Fingers

System	64-Bit Win7/10
CPU	Intel i3 8100 and up
Memory	4GB and up
PCIE Socket	X4 and up
PCI Express	PCI Express2.0 (Gen2) and up
Motherboard PCIE power supply	12V/1A and up

Table 2-3 Motherboard Requirements



2.2 BCL4566E Wiring

The BCL4566E bus height controller uses the EtherCAT bus to control the laser cutting capacitive follower. It is a high-performance capacitive height controller.

BCL4566E Terminal Board		
Module	Qty	Description
Power Supply	/	24V DC /3.5A
DA	2	0-10V, 12bit, ±50mV
PWM	2	5V and 24V, ±50KHz 0.3%
Common Output	24	24V active high 1) The current of single output ≤ 0.7A 2) The current of all outputs ≤ 2.5A
Axis	1	Pulse digital quantity, PUL±/DIR± output, up to 600KHz
Dedicated Input	27	IN1-IN24, active low, 0~ 15V IN25-IN27, active high, 24~ 8V
Capacitance Sensor	1	Capacitance frequency 2Mhz~4Mhz
Working Environment	/	Temperature: 0°C~60°C
		Humidity: 10%~90%RH (no condensation)
Dimension	/	300mm×123×34mm
Weight	/	640g

Table 2-4 BCL4566E Technical Data



2.2.1 Interface Layout

BCL4566E interface layout of terminals

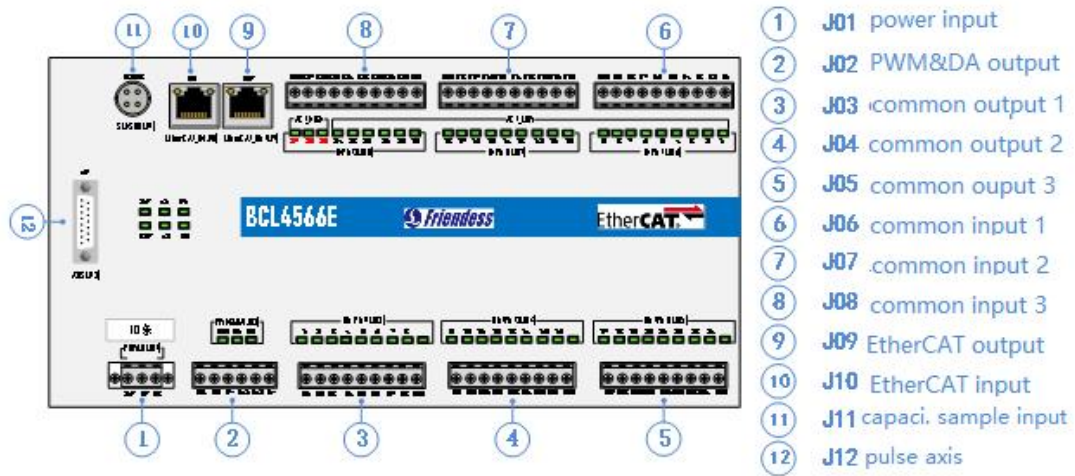

Figure BCL4566E interface terminals

2.2.2 J01 Power Supply

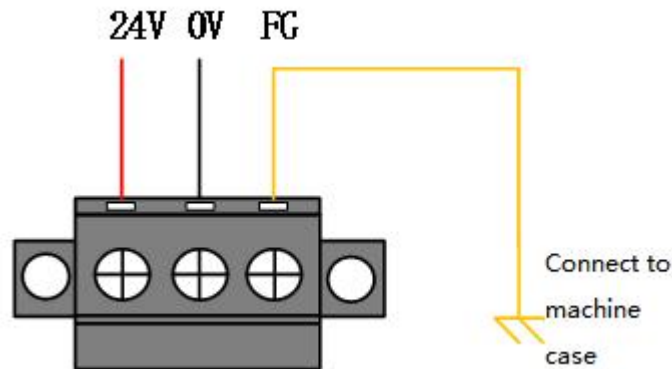

Figure Power Supply Terminal

The machine case is the negative pole of the measured capacitance. In order to ensure the stable operation of the measurement circuit, the "FG pin" of the power interface must be reliably connected to the machine case (that is, it is in good conduction with the machine case). The case of the preamplifier of BCL4566E must also be connected with the machine case well. The specific index is that the DC impedance is always less than 10 ohms, otherwise the EMC effect may not be good.



2.2.3 J02 PWM/DA Terminals

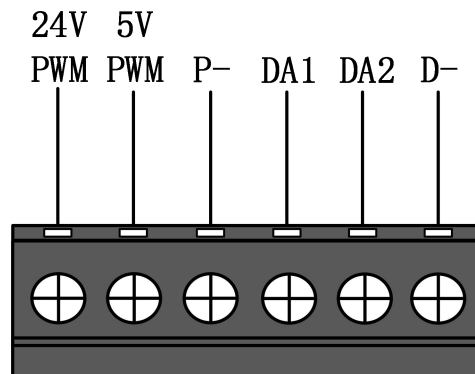

Figure PWM/DA Terminals

BCL4566E has 2 channels of PWM pulse width modulation signal, the left channel is 24V level PWM. The right channel is 5V level PWM, and P- is the negative terminal of the PWM signal. The duty cycle is adjustable from 0% to 100%, and the highest carrier frequency is 50KHz. The signal output mode is shown in the figure below.

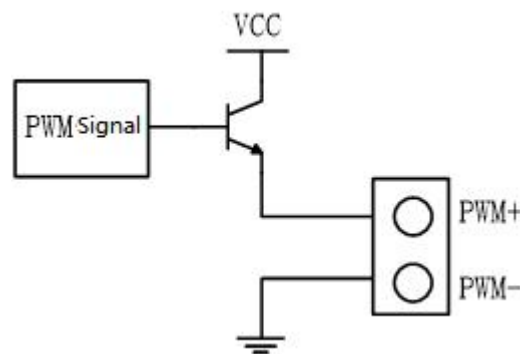

Figure PWM Output Circuit

Note: 1) There are dedicated enabling relays for PWM+ and PWM- signals, and there is no need for external relay isolation.

2) Wrong connection of 5V/24V PWM signal may cause damage to the laser.

BCL4566E has 2 channels of 0~10V analog output. DA1/DA2 is the positive terminal of analog quantity, and D- is the negative terminal of analog quantity. DA1/DA2 can be configured as the control signal of laser peak power and gas proportional valve in the "Cypfig" that comes with CypcutE software.

Output Signal	0V~+10V
Max Output	50mA
Max Error	+/-10mV
Resolution	2.7mV
Conversion	400us



2.2.4 J03/J04/J05 Output Terminal

Take J03 as an example, the interface diagram is as follows.

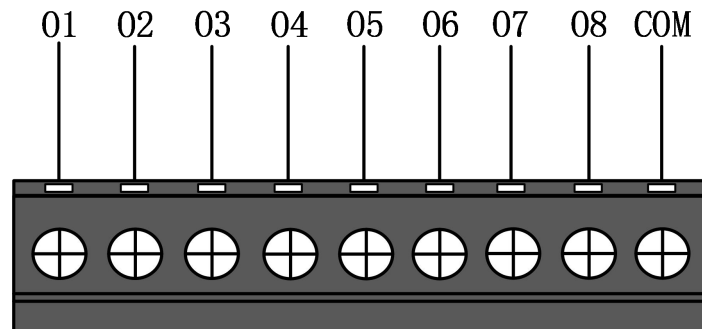

Figure Output Terminal

J03-J05 has a total of 24 high-level (24V level) outputs. The above figure is the wiring diagram of J03. O1-O8 are the positive terminals of the output port, and COM is the negative terminal of the output port. The 24 output ports can be configured as control interfaces, e.g. "laser", "cutting head", "auxiliary gas", "alarm" and "pallet changer" etc. in the "Cypfig" that comes with CypcutE software.

Note: 1) The maximum current of one output port is 0.7A, otherwise the short circuit protection will be triggered.

2) The total current of the output ports cannot exceed 2.5A, otherwise the short circuit protection will be triggered.

2.2.5 J06/J07/J08 Input Terminal

Take J06 as an example, the interface diagram is as follows.

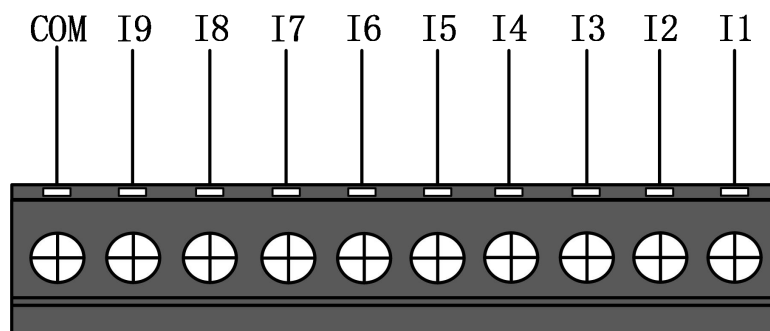
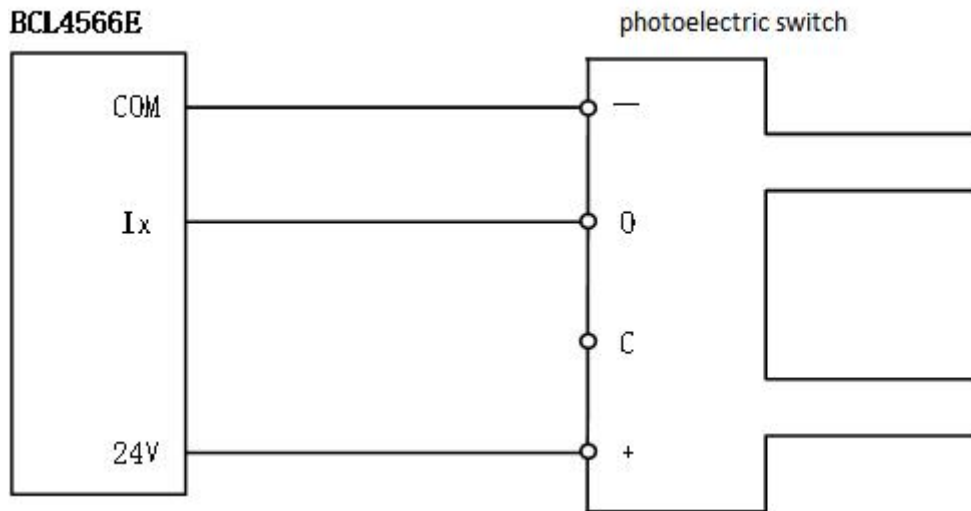

Figure Input Terminal

J06-J08 has a total of 27 input ports. IN1-IN24: active low (0~15V), high level (19-24V) has no conduction; IN25-IN27: active high(24~8V conduction), low level (0~4V) has no conduction. Take J06 as an example, I1-I9 are the positive terminals of the input port signal, and COM is the negative terminal of the input port. The typical connection of the photoelectric switch is as shown in the figure below. An NPN 24V photoelectric switch



should be used.



The typical connection of the contact switch is shown in the figure below.

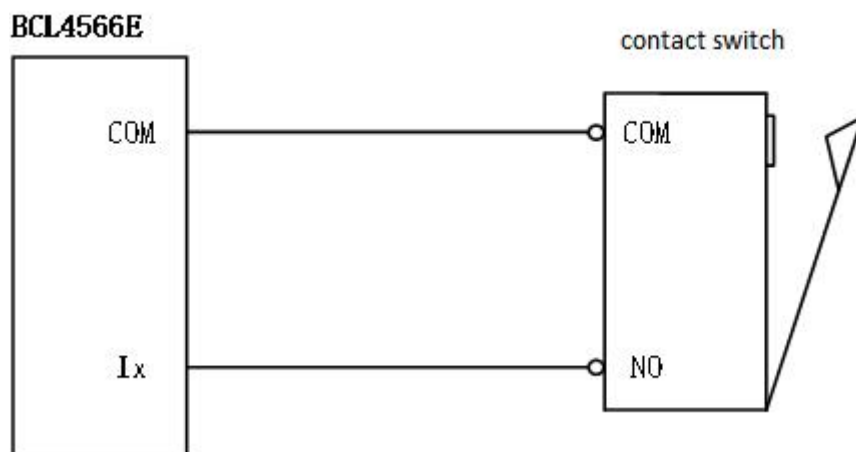

The typical connection of the magnetic induction input switch is shown in the figure below. An NPN 24V magnetic induction switch should be used.

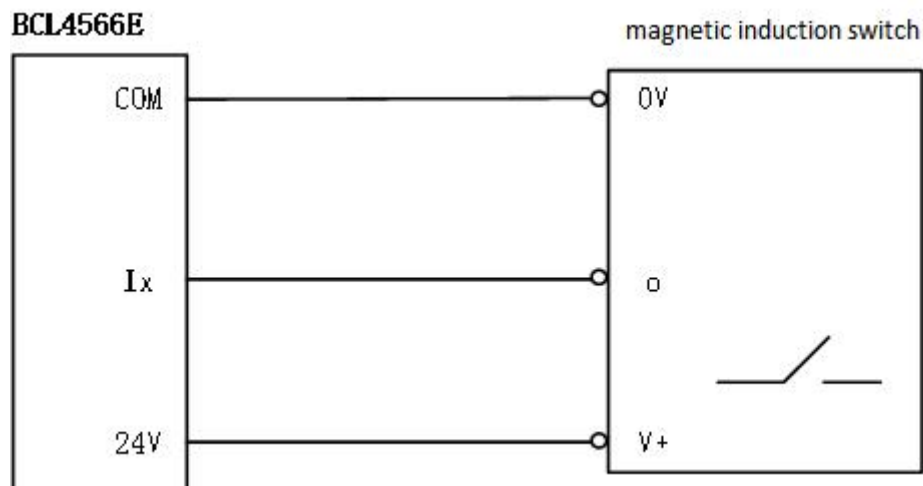



2.2.6 J09/J10 Network

J09 is the EtherCAT network output interface, and J10 is the EtherCAT network input interface, supporting 100Mbps network communication. It is recommended to use standard RJ45 network cables in CAT5E or up for bus communication

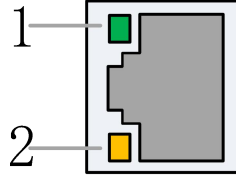

Description of RJ45 connection status of network terminal

Label	Description	LED color	Status	Description
1: Link	EtherCAT Bus Connection and Communication Status	Green	Off	No connection
			Solid	Connected, without communication
			Flashes	Connected, with communication
2: Status	EtherCAT Bus Link Status	Yellow	Off/Flashes	Not in the OP state
			Solid	in the OP state

2.2.7 J11 Sensor

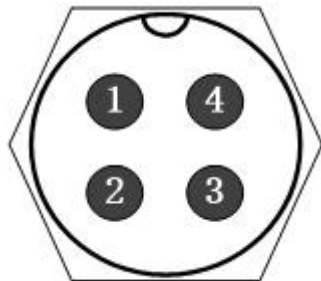

1. Connect to the other terminal 1
2. Connect to the other terminal 2
3. Connect to the other terminal 3
4. Connect to shielding layer

Figure Sensor interface

The 4-core signal transmission cable of the sensor can be made by yourself with a 3-core shielded cable and two 4-pin plugs. 1, 2, and 3 cores are connected in pairs, and the 4th core must be connected with a shielding layer. It is recommended to use the original cable to ensure stability.

2.2.8 J12DB15 Servo Axis Interface

The control interface of BCL4566E focusing servo driver is double-row female DB15F, and the pin definition of the corresponding wire is shown in the figure below:

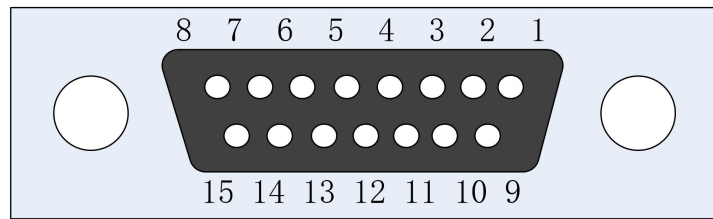

Figure Servo driver interface

Axes are defined in the table below.

Servo Axis Interface Definition

15-pin Female Servo Control Interface			
Pin	Signal name	Pin	Signal name
1 yellow	PUL+	9 yellow black	PUL-
2 blue	DIR+	10 blue black	DIR-
3 black	A+(encoder)	11 black white	A-(encoder)
4 orange	B+(Encoder)	12 orange black	B-(encoder)
5 red	Z+(encoder)	13 red black	Z-(encoder)
6 green	SON(servo enable)	14 purple	ALM(alarm)
7 green black	-	15 brown black	0V(power ground)
8 brown	24V(power output)		

+24V, 0V: 24VDC power for the servo driver.

PUL: digital signal, pulse signal for the driver.

DIR: digital signal, direction signal for the driver.

SON: output servo drive enable signal.

ALM: Receive the alarm signal of the servo drive.

A+, A-, B+, B-, Z+, Z-: three phases of the encoder, input signal.

Please refer to the figure below for the wiring with the Yaskawa servo drive.

Yaskawa Servo Wiring

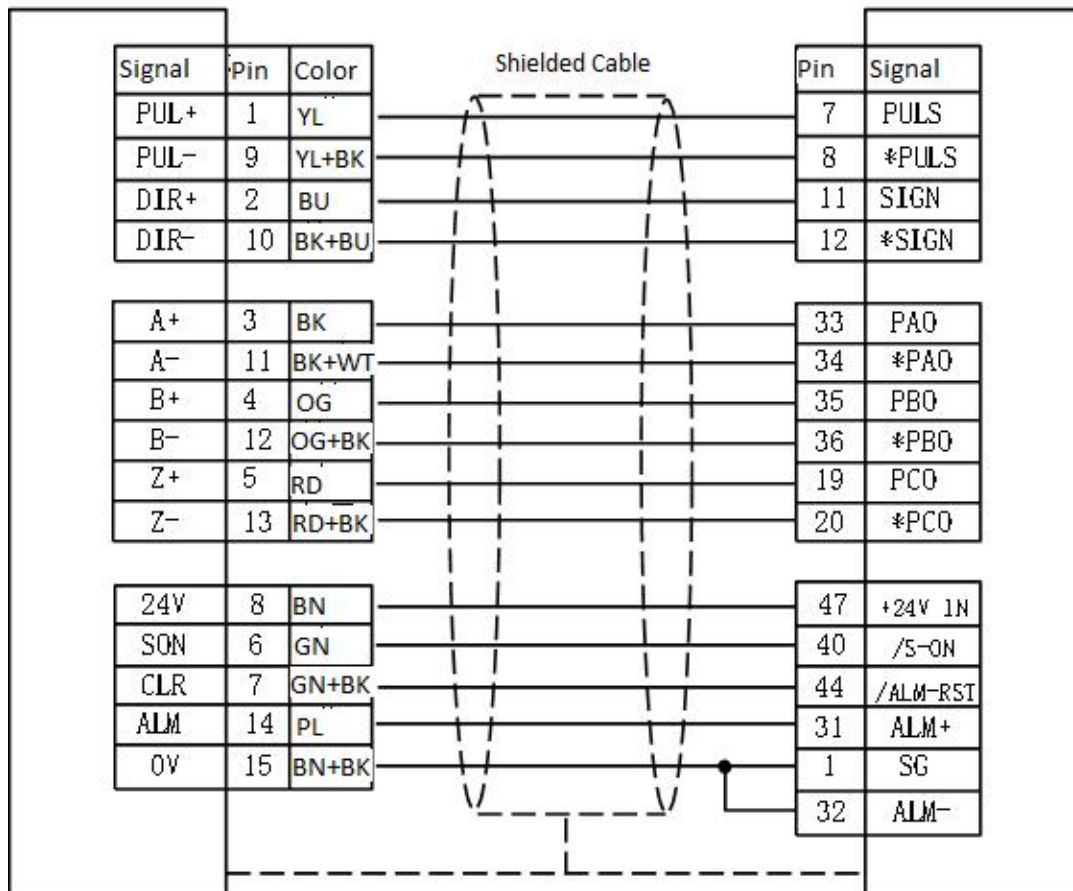

Figure Yaskawa Servo Wiring Diagram

Pay attention to the following when connecting drives in other brands:

1. Please first confirm the type of SON signal of the servo driver you choose and whether it is active low (that is, it is ON when it is connected to the GND of the 24V power supply).
2. Make sure the parameter of the servo driver: the pulse signal received is "pulse + direction".
3. Confirm whether there is an external emergency stop signal input in the input terminal of the servo driver, and its logic.
4. Before the test run of the driver, 24V power must be supplied to the terminal board first, because the 24V power required by the servo is transferred through the terminal board.
5. If the driver still cannot run, make sure that the parameter is set to not use "POT/NOT".

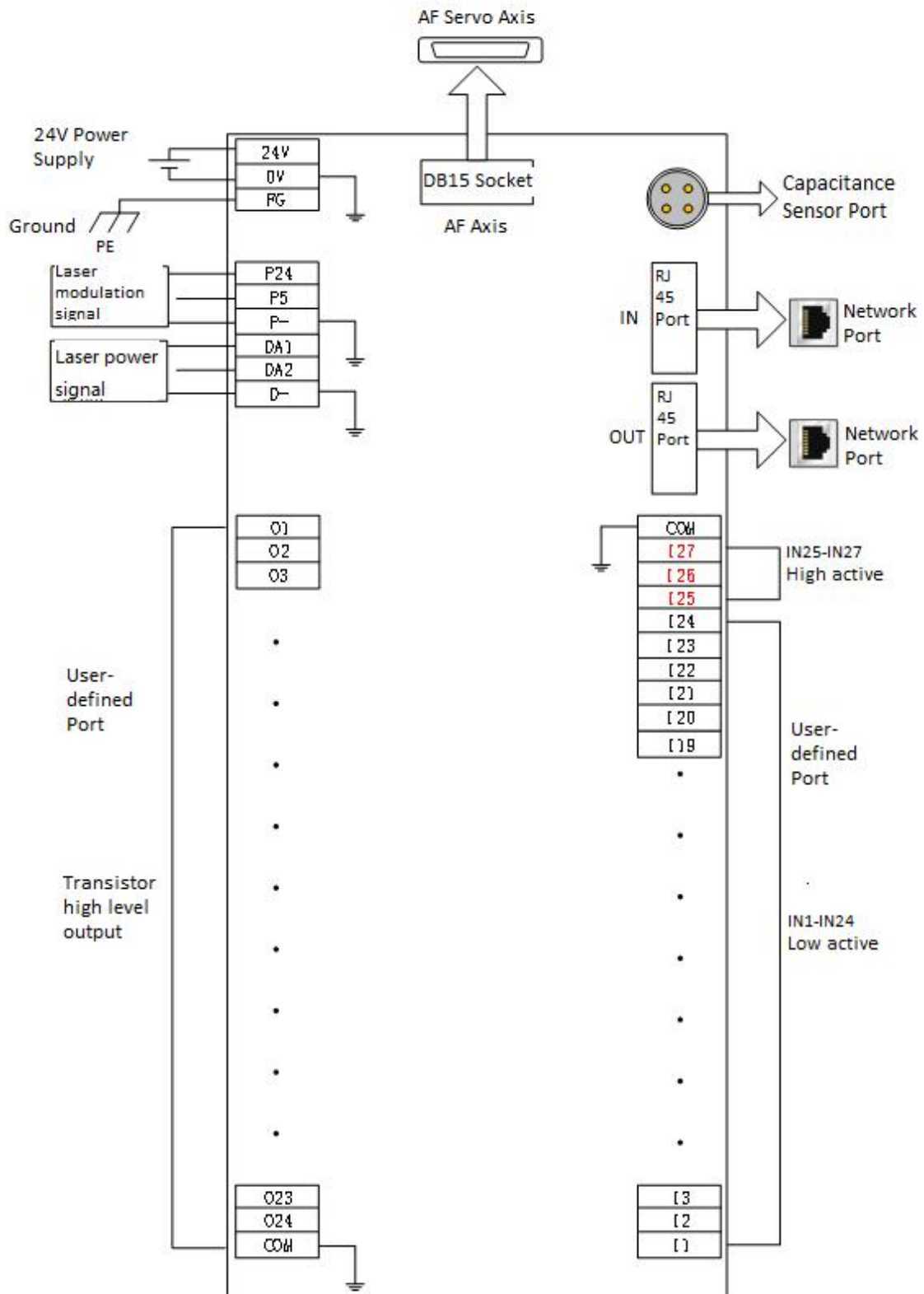

Figure BCL4566E Wiring Diagram



2.3 Cutter Wiring

2.3.1 ProCutter Wiring

The connection of ProCutter cutting head is shown in the figure below.

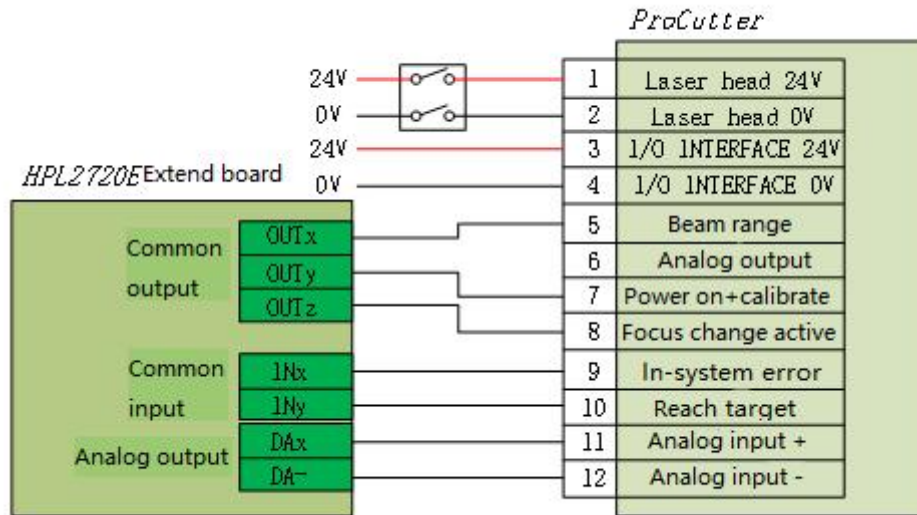



2.4 Laser Wiring

2.4.1 IPG_YLS Germany

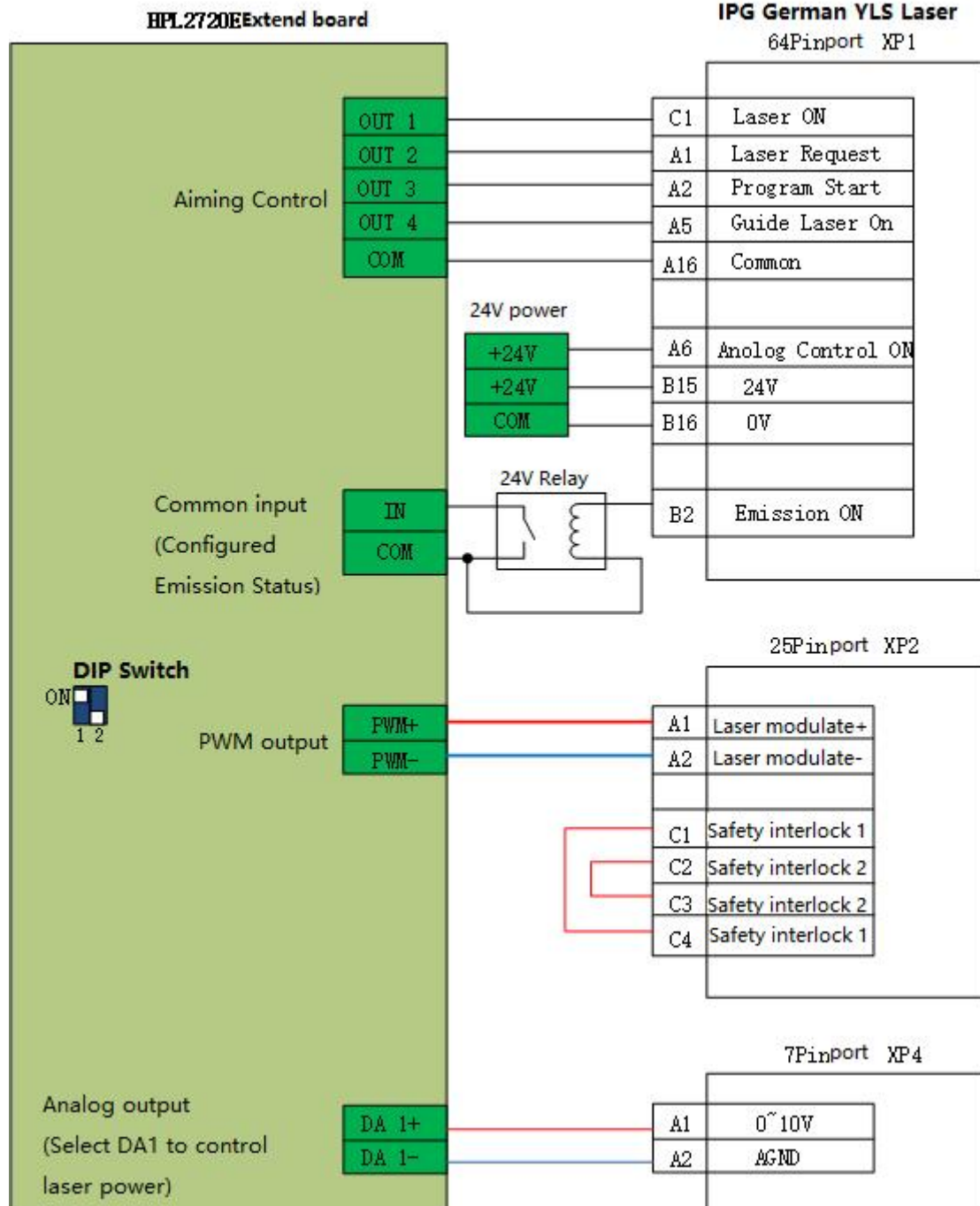



2.4.2 IPG American

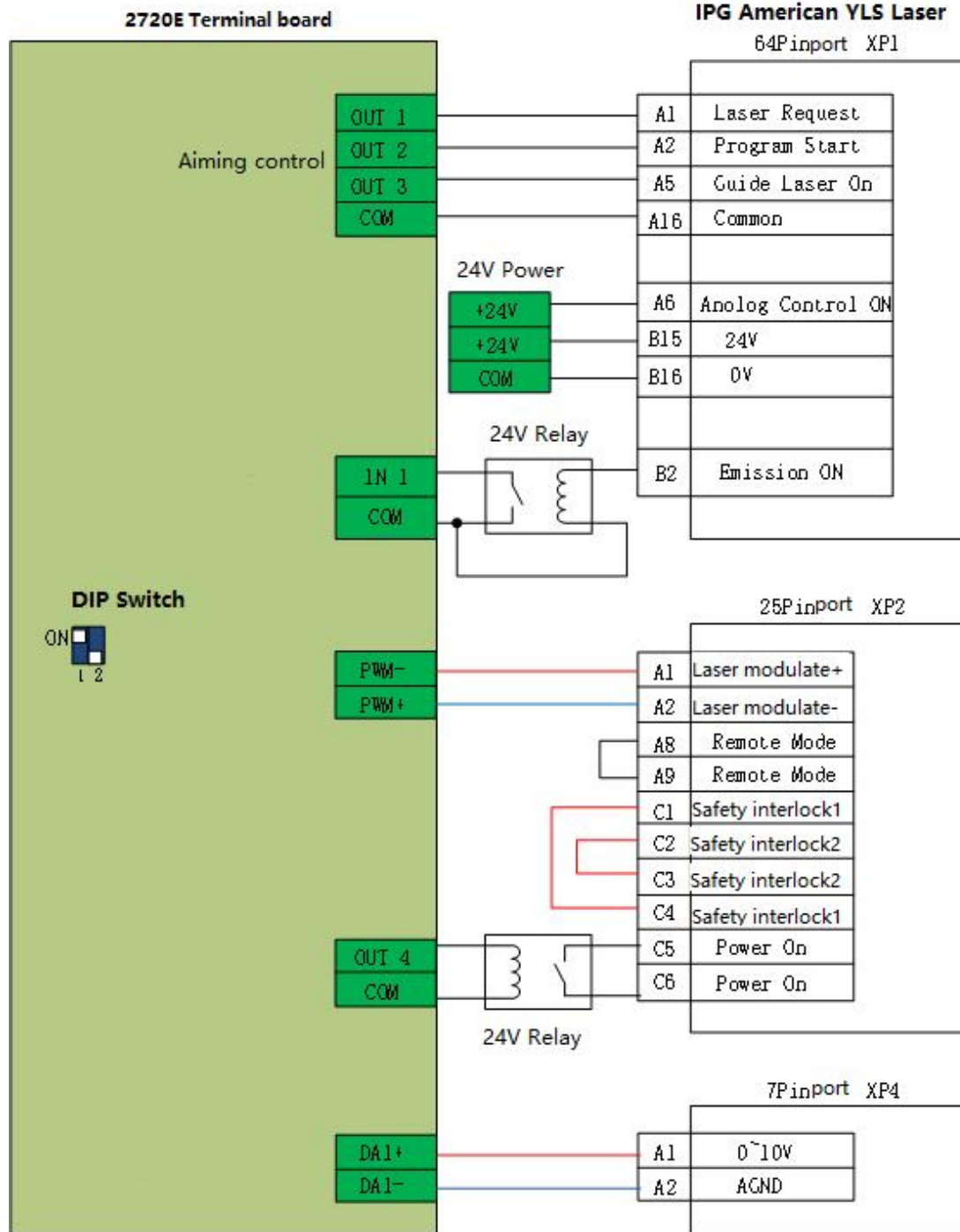



2.4.3 RayCus

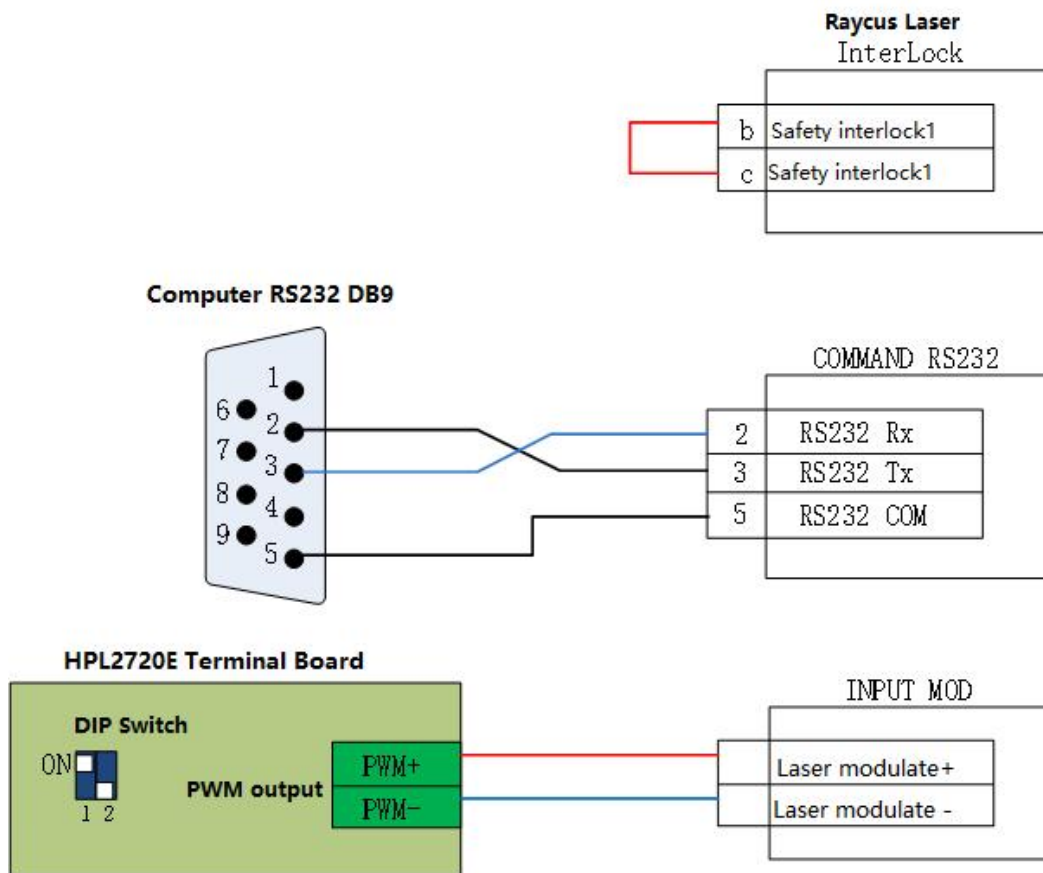



2.4.4 Trumpf

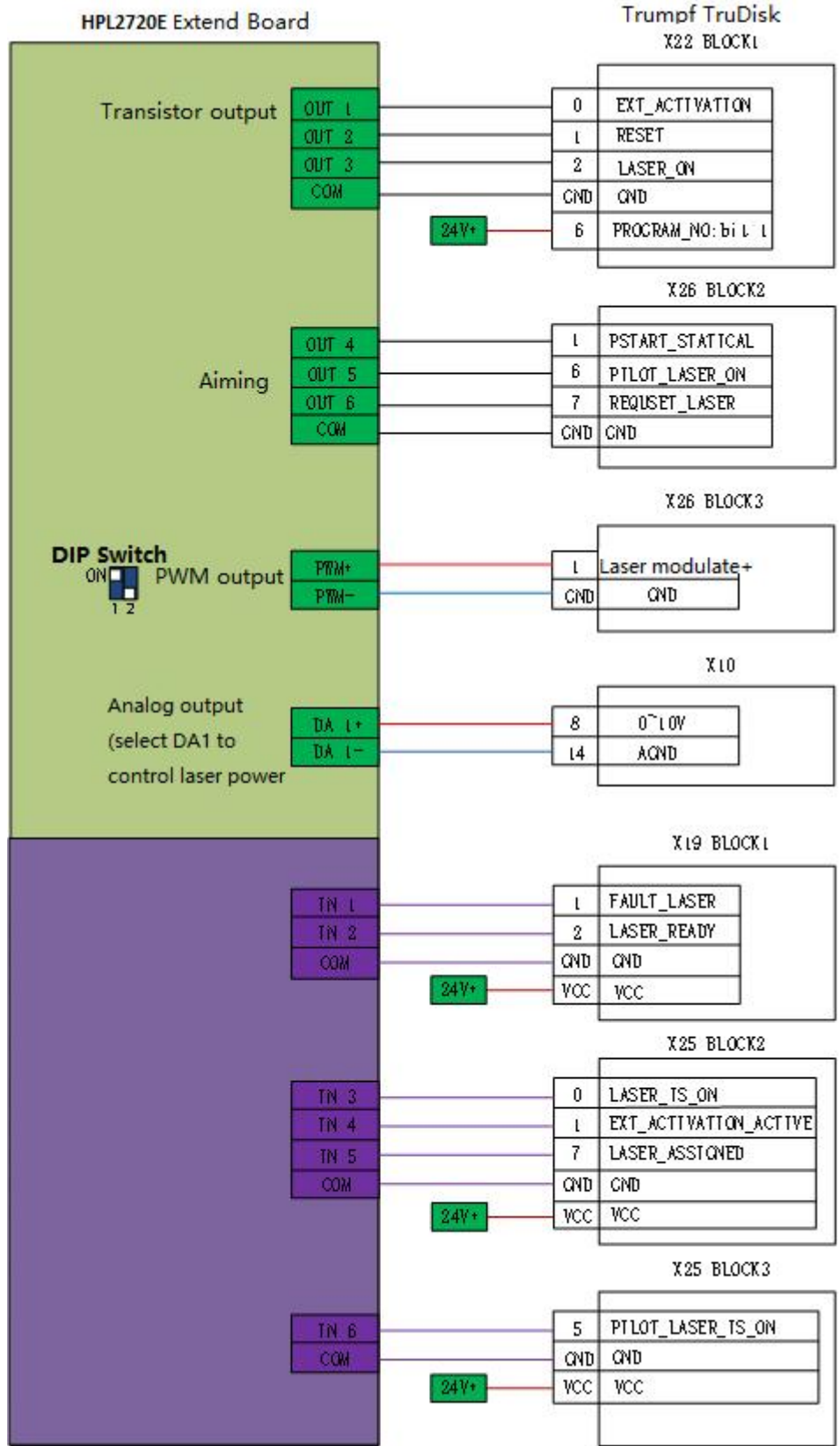



Chapter III Installation

3.1 Installation Steps

3.1.1 Step 1. Install BMC2283 Control Card

- (1) Power off the host.
- (2) Open the host case, select a free PCIE slot, and use a screwdriver to remove its slot.
- (3) Insert BMC2283 into the slot. The installation is shown in 2.1.2.
- (4) Tighten the screws of the BMC2283 block with a screwdriver.
- (5) Cover the case, turn on the power of the host PC, and start the host.

3.1.2 Step 2. Install BMC2283 Driver

2 ways to install BMC2283 driver.

1. Use TubePro to install the driver, check the driver when installing TubePro, as shown in Figure. The BMC2283 driver will be automatically installed.

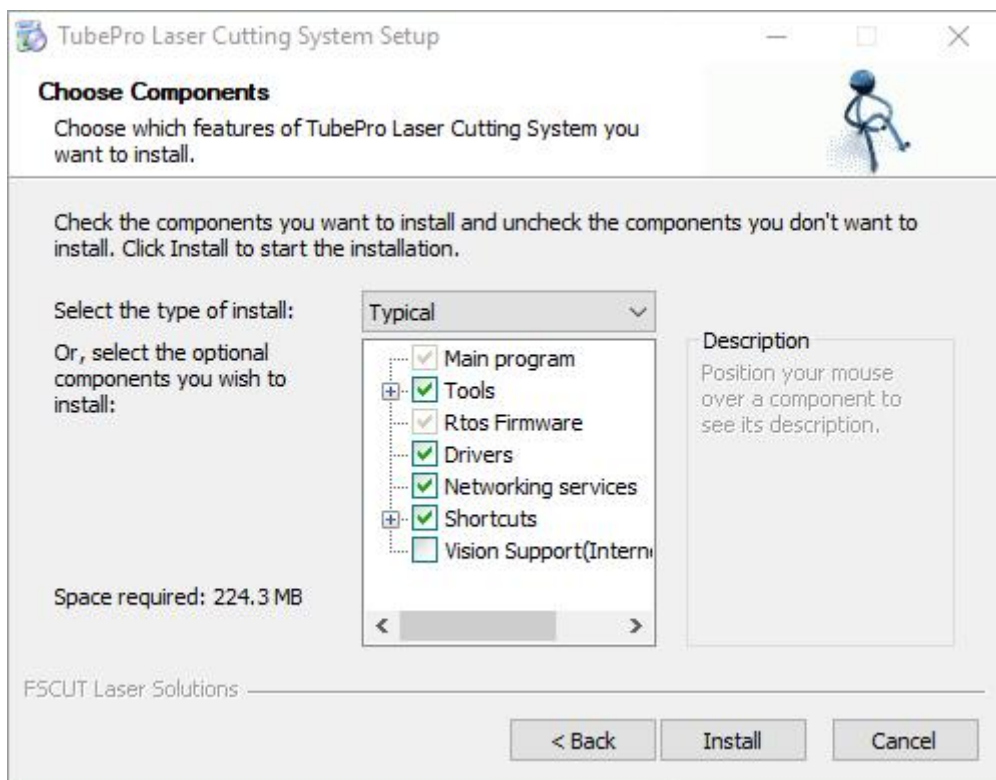

Figure Check Driver Program

2. Open the "Device Manager", it will display "Other Devices" as shown in Figure, if its driver is not installed.

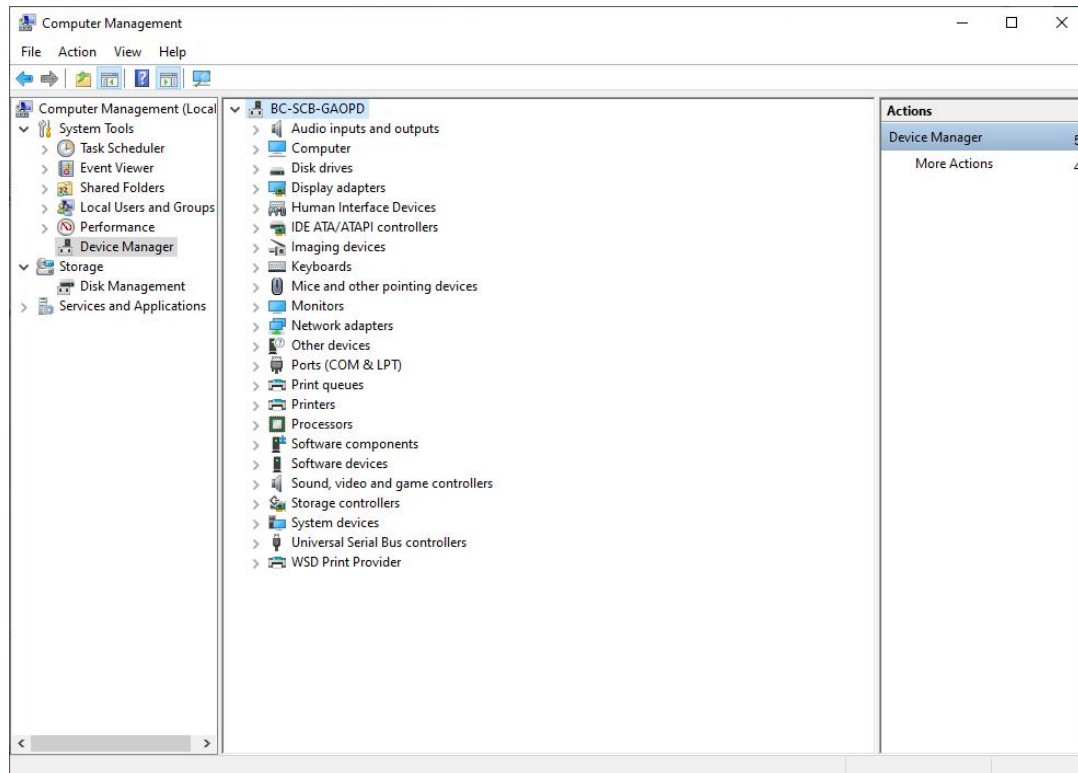

Figure Unknown Device

Right click on "PCI FLASH Memory" and select "Update Driver Software", as shown in Figure.

Select TubePro and find the default location of driver files: C:\Program Files (x86)\Friendess\TubePro\Drivers_E, then click Next, as shown in Figure.

The driver installation is complete, if "BMC228X DMA" is displayed as shown in Figure.

3.1.3 Step 3. Connect Slave

Use CAT5E or above standard network cable (Friendess network cable recommended) to connect the slave the wiring diagrams of BLT series cutting head and other cutting heads are shown in section 1.2.

3.1.4 Step 4. Scan in Machine Config Tool

Open "Machine Config Tool" and click "BUS Scan"->"Start". The system will scan the connected slave information.

3.1.5 Step 5 Use TubePro

After setting the parameters in the "Machine Config Tool", open TubePro, import the graphics, and set the process parameters, then it can be processed See the software manual for details.



Chapter IV Precautions

4.1 Wiring Precautions

4.1.1 Drag Chain Wiring

- When releasing the 4-pin cable from the coil, it is necessary to prevent the cable from twisting (the cable must be released along the tangential direction) and the cable must be laid straight. This work should be done before laying the cables, to give the cables time for stress relief. Because the manufacturing process cannot completely guarantee that the cable is straight and free of distortion, the printed logo on the surface of the cable rotates in a tiny spiral.

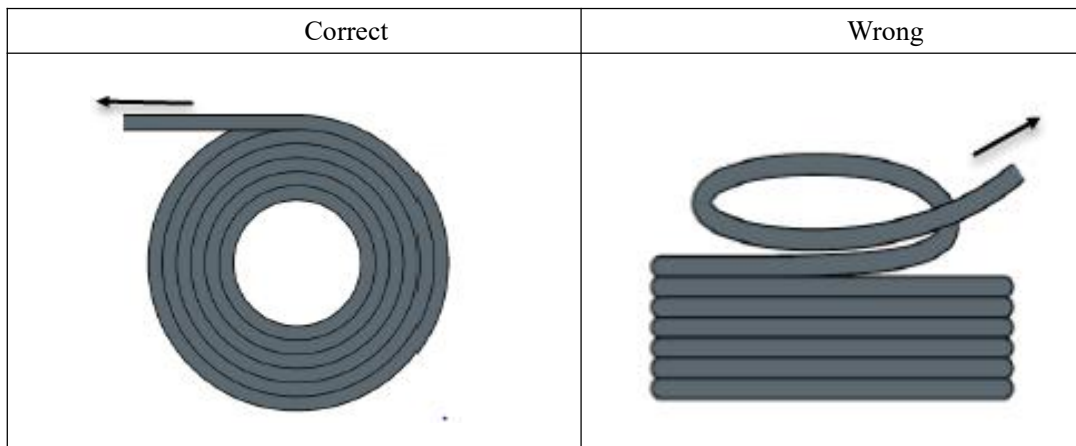

- Cables are not allowed to be twisted when installed in a closed space, and twisting during installation may cause damage to the core wire stranding. This effect is gradually strengthened during the operation of the cable, resulting in back-twisting, which eventually leads to the breakage of the core wire and failure.
- The cables must be laid loosely next to each other in the drag chain support. Spacers should be used to separate the cables as much as possible. The space between the cable and the spacer, separator and the cable adjacent to it, shall be at least 10% of the diameter.

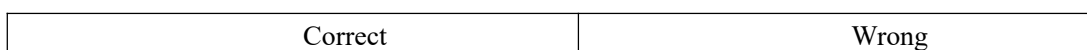

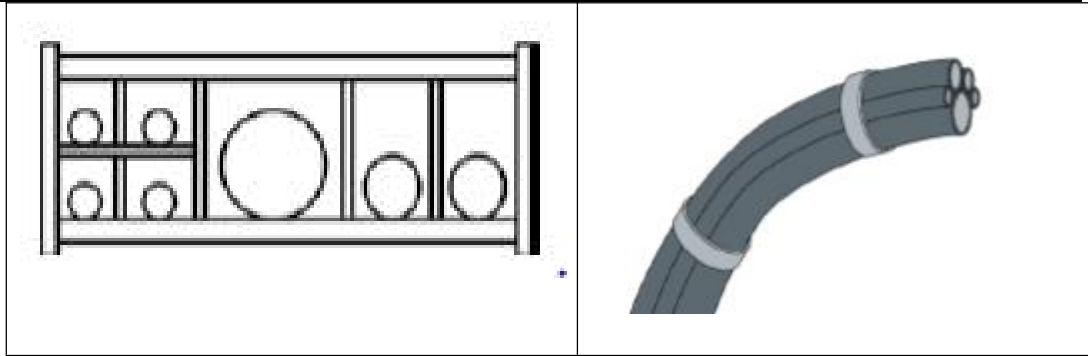

4. The cables should be installed according to the weight and size of the cables. The larger diameter and heavier cables should be placed outside; the smaller diameter and lighter cables should be placed inside. The cables can also be placed from the inside to the outside descendingly by size. Do not place one cable on top of another without using a spacer.
5. For vertically suspended drag chains, keep more free space for the vertical support, because the cables will be stretched during operation. After a short run, it is necessary to check that the cables run along the center area and adjust them if necessary.
6. For self-supporting drag chain, cables are fastened to moving and fixed points. Suitable cable supports from the supplier are required. Cable ties have very limited applicability when operating at high accelerations. So you should not bundle multiple cables together. Cables should not be fixed or tied to any moving parts of the drag chain. The gap between the fixed point and the bending area should be wide enough.

**self-supporting****sliding**

7. It is recommended to fix the cable on the moving point for sliding drag chains. A small cable protection zone is required at the fixing point. (Refer to the instructions from the drag chain supplier)
8. Please ensure that the cable runs along the center area with the desired bending radius. Do not apply tension to the cable (do not pull it too tightly), otherwise the friction inside the drag chain will cause the cable sheath to wear; do not let the cable be too loose in the drag chain, otherwise it will easily cause abrasion of the cable and the inner wall of the drag chain, or tangled with other cables.

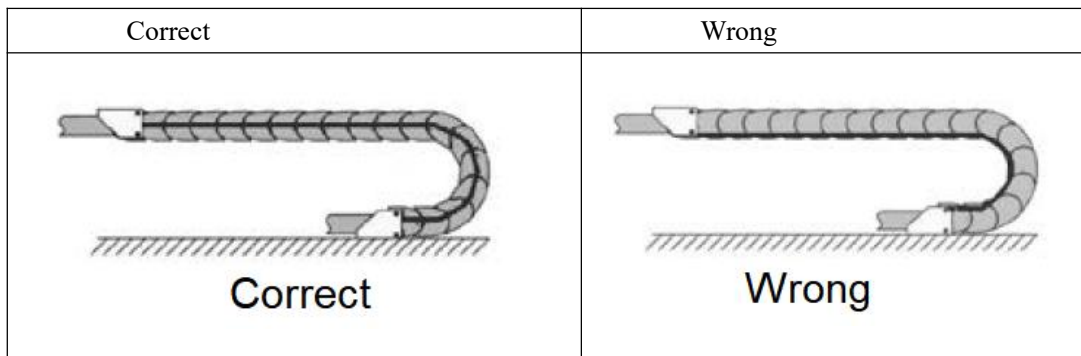

9. If the cable does not run smoothly, check whether it is twisted along the longitudinal axis during operation. The cable should slowly rotate at a certain fixed point until it runs freely.

10. Given the size of cables and drag chains, their length characteristics vary considerably. During the first few hours, the cable naturally elongated. For drag chains, it takes more hours for this to happen. Such a large discrepancy can be remedied by regularly checking the cable installation locations. It is recommended to do regular inspections, every three months for the first year and at every maintenance thereafter. This includes checking that the cables are completely free to move within the intended bending radius and making adjustments if necessary.

4.1.2 Machine Tool Wiring

1. Power Supply (Power) Wiring

(1) Strong Electricity

- Strict separation of strong and weak electricity

Select the appropriate diameter for the power cable according to the power. The table below is the cable diameter and its corresponding power.

Cable Spec(mm ²)	Cross Section(mm ²)	25°C Copper Wire Ampacity (A)	Single-phase 220v load power (W)	Three-phase 380v load power (W)
1.5	1.38	15	3300	9476.8
2.5	1.78	25	5500	13163.2
4	2.25	32	7040	16848.8
6	2.85	45	9900	23693.6
10	7*1.35	60	13200	31591.2
16	7*1.7	80	17600	42121.6
25	7*2.14	110	24200	57917.6

- Add auxiliary devices such as short-circuit protectors and filters for strong electricity.

(2) Weak Electricity (DC24V for example)



- Distinguish the positive and negative wires of the power supply in color, e.g., the red wire is connected to the positive pole, and the blue wire is connected to the negative pole
- Loads with relatively large interference (e.g. servos and solenoid valves) are powered separately from the controller.

2. Grounding

- **The ground wiring adopts the standard two-color, yellow and green, wires.**
- It is recommended to use multi-point grounding, for some high-frequency signals (PWM, pulse, encoder, capacitance, etc.) in the laser cutting machines.
- The machine tool uses galvanized grounding screws and a special grounding wire for grounding. The resistance between the grounded metal body and the main grounding point should be $\leq 0.1\Omega$.

3. Signal (Control)

- Signal wire color, e.g. black.
- Choose the signal wire according to the power.
- DC 24V solenoid valve is recommended. Add absorption circuits at both ends of the solenoid valve, that is, connect a freewheeling diode in parallel at both ends of the solenoid valve (pay attention to the direction, withstand current, and withstand voltage), as shown in the figure below.

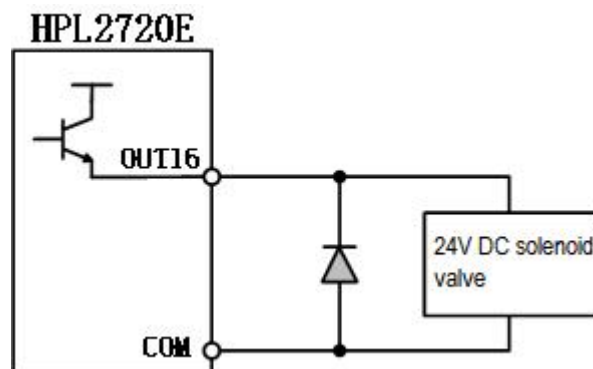

- It is recommended that the digital signal (PWM) shielding layer be grounded at both ends, and the analog signal (DA) shielding layer be grounded at one end. Single-ended grounding can avoid low-frequency current noise on the shielding layer; double-ended grounding can effectively eliminate high-frequency interference. If the transmission cable is very long, it is recommended to ground at multiple points to ensure that the shielding layer is at the same potential.
- The resistance from the cutting head connected to the amplifier to the shell of the machine tool is $\leq 1\Omega$, and the resistance to the grounding point of the electrical cabinet is $\leq 6\Omega$.

4. Notes



- Each cable is marked clearly and accurately.
- Cables are in parallel and not crossed, and the harnesses should be straight and leveled.
- If using the cables from Friendess, choose the appropriate cable according to the layout space, and do not pile up and circle it.
- All wiring must be firm to prevent sparking.
- Wiring should avoid loops and antenna effects. The current loop composed of signal source---transmission line---load is equivalent to a magnetic field antenna. As shown in the figure below, the wrong connection is on the left, and the correct connection is on the right.

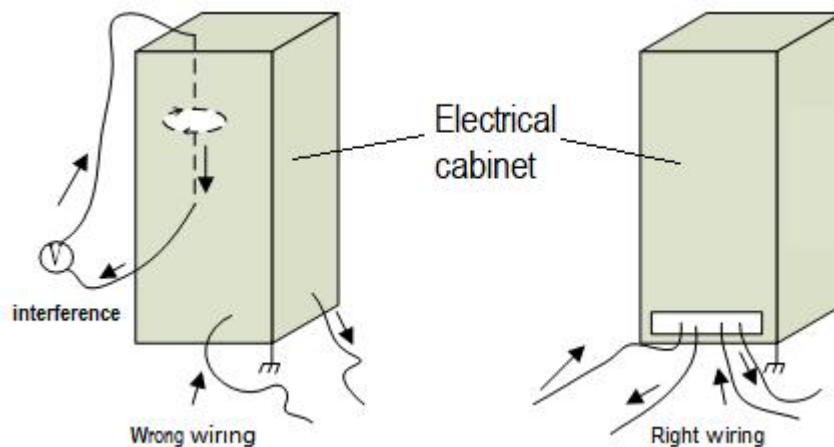

4.1.3 Assembly Requirements

	Handle with care. Please wear anti-static gloves or touch a grounded metal object to prevent static electricity from damaging the motion control card before touching the control card circuit or inserting/pulling the control card.
	Except for the USB interface, plugging and unplugging with power is prohibited for other interfaces, which may cause internal components damaged.
	Handle with care. Do not press the card. Pressing might cause the card to bend and its function damaged.

4.2 Troubleshooting

4.2.1 Device Manager cannot find PCIe devices

If the device manager cannot find any PCIe devices:

1. Check the status of the indicators on BMC2283. The positions of the power indicator and system status indicator are shown in Figure

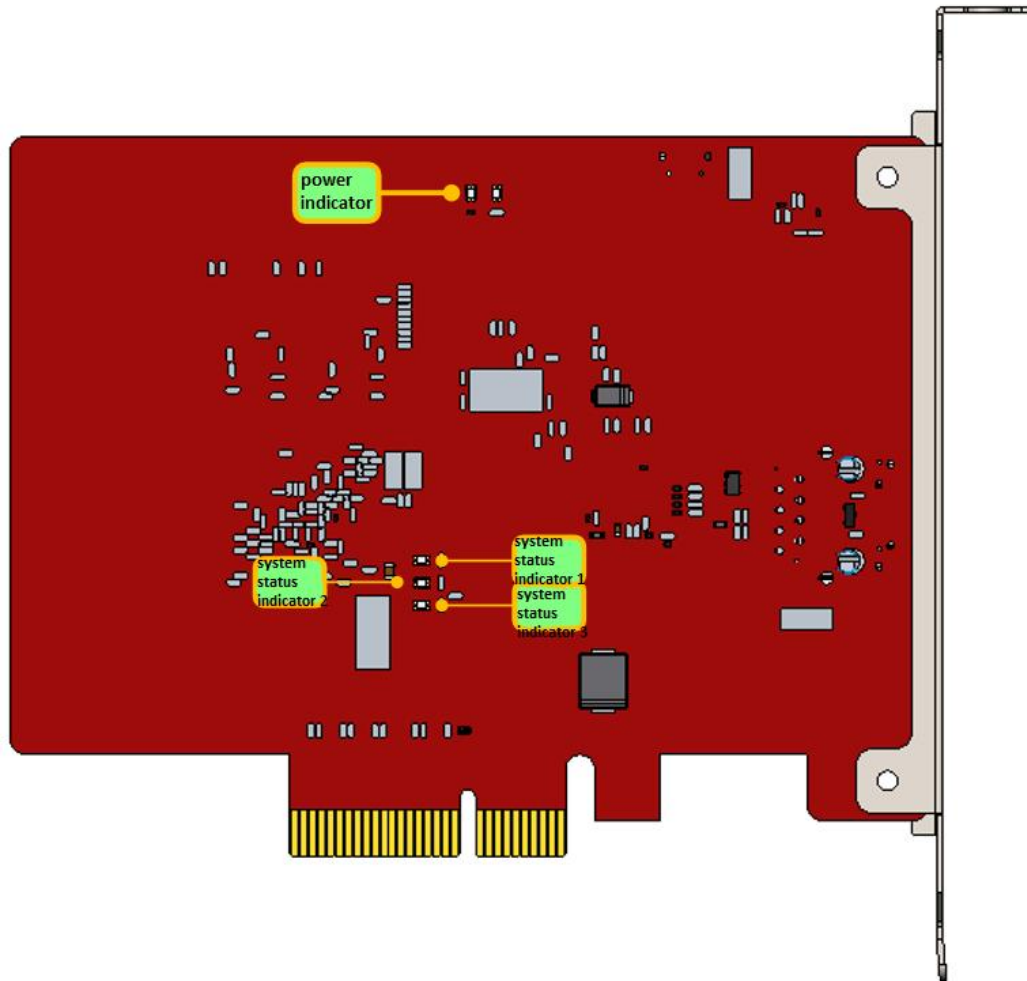

Figure BMC2283 Indicators

If it is not in the OP state, the power indicator is always on, both the system status indicator 1 and the system status indicator 2 flash at 1 Hz at the same time, and the system status indicator 3 is always on.

If it is in the OP state, the power indicator is always on, the system status indicator 1 and system status indicator 2 flash alternately at 1 Hz, and the system status indicator 3 is always on.

If the BMC2283 status indicator is abnormal, change the card and try again.

2. If the BMC2283 status indicator is normal, change a card slot or host computer to scan again
3. If the PCIe device still cannot be found, contact our customer service.

4.2.2 Device Manager cannot install driver

If PCIe devices are in the device manager, but the BMC228X driver is not recognized:

1. Please manually install the driver again according to section 3.1.2.
2. If the driver is still not installed, change a card slot or install the driver on the host.
3. If the driver is still not installed, contact our customer service.

4.2.3 Bus Scan failed

If the Cypfig failed to scan the slaves:

1. Check whether the EtherCAT bus servo and slaves are powered on.
2. Check whether the network cable installed securely.



3. Check whether the slave device is supported. If not, contact customer service. If yes, change the slave device and scan again.
4. If still failed, contact customer service

4.2.4 Bus network alarm

Common Bus Network Alarms and Solutions

Alarm	Reason	Solution
Bus network alarm, the network cable is not connected 0x9811002D	The slave device is not powered on or the network port is connected incorrectly	Check the power supply of the slave device and the wiring of the network port
Watchdog timeout alarm	Communication between TubePro and BMC2283 timed out	If it is automatically released, it can be ignored; if it occurs during processing, record the operation steps and give feedback to our customer service.
Bus network alarm, network mismatch 0x9811001E	The network cable between the EtherCAT network port of the computer and the slave is loose or the power supply of the slave is disconnected	<ol style="list-style-type: none"> 1. Check the wiring of the EtherCAT network port 2. Sort out the wiring and check for interference 3. Check the power supply of the slave
Bus network alarm frame lost 0x98110025	EtherCAT network communication data frame loss	<ol style="list-style-type: none"> 1. Check the wiring of the EtherCAT network port 2. Sort out the wiring and check for interference 3. Check the power supply of the slave
Bus network alarm, the slave is not in OP state	The Nth slave is abnormal, the network cable between the N-1 slave and the Nth slave is loose or interfered	<ol style="list-style-type: none"> 1. Check the wiring of the EtherCAT network port 2. Sort out the wiring and check for interference 3. Check the power supply of the slave
Bus network alarm, network timeout 0x98110010	EtherCAT network communication data frames are lost continuously	<ol style="list-style-type: none"> 1. Check the wiring of the EtherCAT network port 2. Sort out the wiring and check for interference 3. Check the power supply of the slave

Table 4- 1 Master card bus alarm and solution