



# Standalone Motion Controller DDCS V2.1 User's Guide



Digital Dream CNC Co., Ltd.  
[www.ddcnc.com](http://www.ddcnc.com)

# 1 DDCS V2.1 Controller Introduction

## 1.1 Introduction of Product

Digital Dream has a 20 years history in the numerical control industry, specializing in the research, development and production of various CNC (Computer Numerical Control) systems. Digital Dream aims to combine high quality and high reliability with affordability. We produce 1 axis to 6 axes CNC system.

The **DDCS V2.1** is a 4 axis motion controller for stepper and servo systems. We are very proud of this product, it combines great power with a tiny footprint and is easy to use. After a very short time you will be familiar with the functions and this manual will help you. The highest output pulse per axis is 500KHz. The pulse width is adjustable (refer to driver manual). The control period of each position is only 4 milliseconds. This provides high control precision for stepper motors and servo motors.

The DDCS V2.1 numerical control system adopts the ARM+FPGA design framework. ARM controls the human-computer interface and code analysis and the FPGA provides the underlying algorithms and creates the control pulse. This guarantees reliable control and easy operation. The internal operating system is Linux based.

The panel layout structure of the DDCS V2.1 is very rational to save space. All operations are controlled by only 17 keys and a comprehensive G code set is supported.

The DDCS V2.1 can be used for many styles and types of CNC machines. Lathes, Routers, Pick&Place and Mills are just a few examples. The DDCS V2.1 operates as a Stand Alone system without the need of a computer. This guarantees high precision, accuracy and reliability. The interface, even very comprehensive, can be learned in a very short time.

## 1.2 Performance parameter of the Digital Dream **DDCS V2.1**

- 1) 16 opto isolated digital inputs
- 2) 3 opto isolated digital outputs
- 3) Analog spindle control 0-10V spindle control (can be modified as PWM output)
- 4) 4 axis motor control, max 500KHz per axis
- 5) ARM9 main control chip
- 6) FPGA core algorithm chip
- 7) 4.3 inches TFT screen, resolution ratio: 480x272
- 8) 17 operation keys
- 9) 18V-32V power input, minimum 0.5A
- 10) USB flash disk support for G code file input
- 11) 1GB internal memory
- 12) MPG port for our MPG with digital display. Many other MPG's also supported
- 13) Jog function for each axis (continuous, step, defined distance
- 14) Support the operation of quickly specify the running position
- 15) Support for "Power Cut" recovery. Data is automatically saved.

## 1.3 Appearance, Structure and Size of Product

The DDCS V2.1 is a small box that can fit in a window of a small control box or control cabinet. Two locking hooks fix this controller from the inside. The dimension you find in picture 1-1 and picture 1-2.

The front panel is 163mm\*102mm\*5mm;

The main body is 156mm\*93mm\*45mm;

To mount the unit in an equipment cabinet, cut the hole 156mm\*93mm



Picture 1-1 DDCS V2.1 Front external view and dimensions

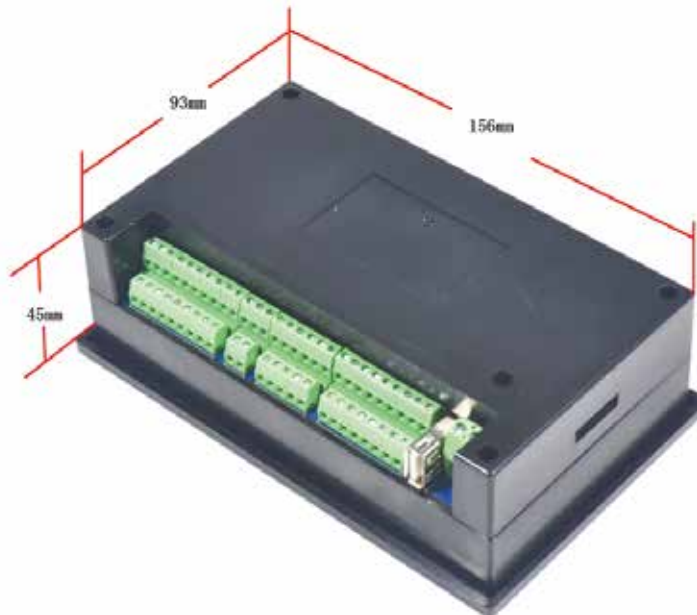

Picture 1-2 DDCS V2.1 Rear view and dimensions

The front panel consists of 17 user keys and the 4.3" (480\*272) LCD. The rear side provides screw terminals for power (18-32V), input signals, spindle control, pulse and direction for 4 stepper/ servo drives, MPG, four programmable interfaces as well as an USB input. Please see the reference picture 1-3 and picture 1-4 in detail.

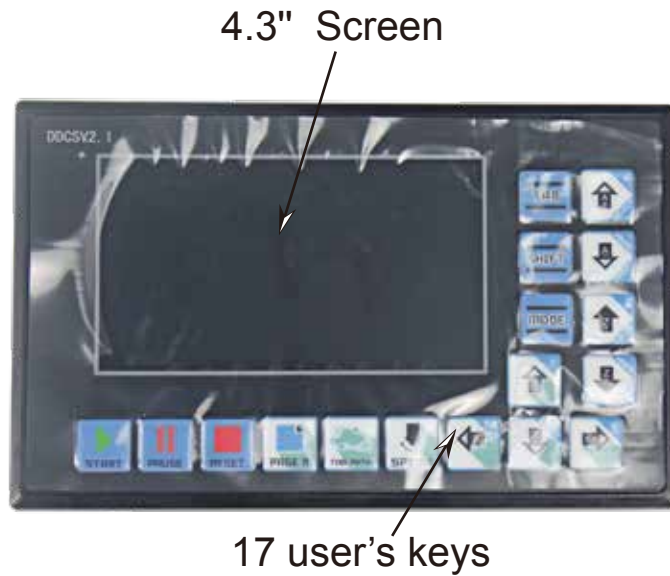

Picture1-3 Front panel

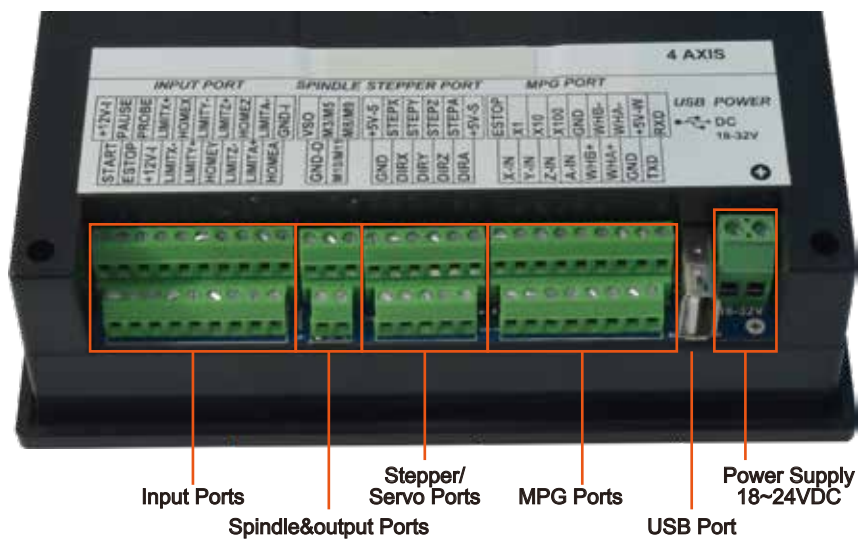

Picture 1-4 Rear view

## 1.4 Explanation of Abbreviations

When operating the DDCS V2.1, the users will come across some English abbreviations. Here a list with explanations

FRO: Feed Rate Override

SRO: Spindle Rate Override

SRJ: Jog Speed Setting

F: Feed rate, unit is mm/min

S: Spindle Speed, unit rev/min.

X: The coordinate code of the X axis.

Y: The coordinate code of the Y axis.

Z: The coordinate code of the Z axis.

A: The coordinate code of the A axis

BUSY: The system is busy. You still can adjust FRO and SRO

READY: READY mode, any operation can be done

RESET: Reset mode, controller is in “OFF” mode, no operation can be performed

CONT: Continuous mode, each axis can be manually jogged with the arrow keys

Step :Manual Step Mode, each axis can be jogged in defined steps

MPG: MPG mode. Operate the machine with the MPG (Manual Pulse Generator)

AUTO: Run G code. Auto is showing when file is processing

## 1.5 Notes and Warnings



Keep away from exposure to moisture or water. This product contains sophisticated electronics and must not get wet.

Wiring warning: the IO input terminal of this controller supports equipment with source power (such as Inductive Proximity Switch ). When using this kind of equipment, pay attention to the polarity. Avoid the +terminal to be connect with GND. This controllers has analog output for spindle control (0-10V). Please avoid this terminal to ever connect with GND as damage to the controller may occur.



Operation warning. Please observe all security measures when operating the machine. The ESTOP must be connected and properly labelled. In case of a problem, press the E-stop at once to avoid damage to humans, animals and the equipment.



High voltage danger. The DDCS V2.1 is connected to 18-32V DC. Obey and follow the electricity safety rules of your country when connecting this equipment.

## 2 Wiring

### 2.1 Power supply explanation

In general, the power supply of industrial control's equipment products are complex. They have many different ground levels. The internal power structure of this product is as follows:

See picture 2-1. The Master Power input and MPG module and stepper control module have the same ground. Limit,ESTOP and other input modules as well as the spindle speed control output /M3/M8/M10 and other output modules have the same ground, which use optical isolation. The Limits, E-STOP and other input modules are connected with the same positive. The controller provides 12V as the common + port, without the requirement of the external power source. As for the spindle port, take the output ground for references and the 0-10V adjustable voltages to adjust the spindle speed (refer to spindle VFD manual). The M3/M8/M10 digital output ports pull to ground. You can connect an external relay with up to 50mA direct to 12V+ and the M connector (Solid State relays usually pull between 15 and 20mA)

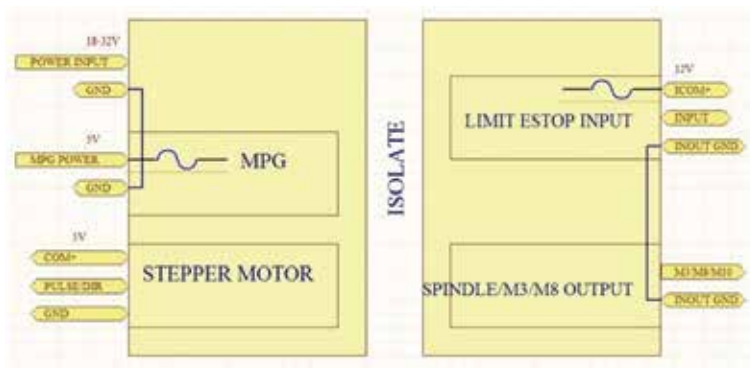

Picture 2-1 Power supply structure

### 2.2 Product Wiring

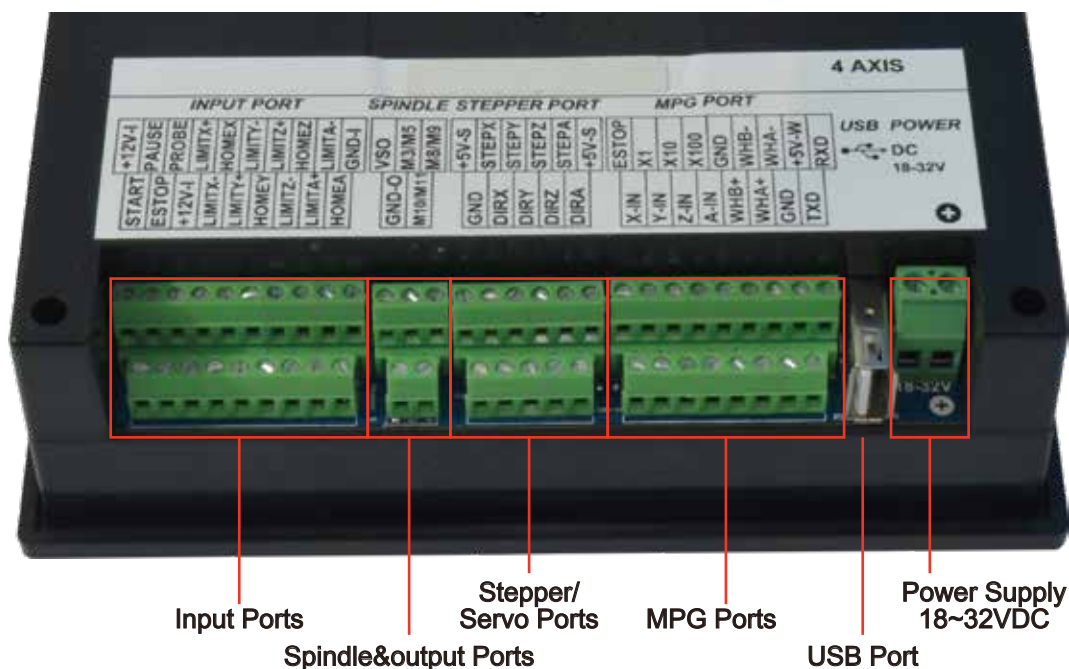

Picture 2-2 Wiring and Ports

As the picture shows, the wiring section of the controller has Input Ports, Spindle&Output Ports, stepper/Servo control step and direction output, MPG Port, USB Port and Power supply Port.

## 2.2.1 Power Supply Wiring

As Picture 2-3 shows, the power interface, a 5.08mm screw terminal. The right terminal is the positive power, the left wiring terminal is the negative power.

Use 18V-32V±0.5V. The current must be equal or >0.5A



DC 18V~32V  
be equal or >0.5A

Picture 2-3 Power supply Wiring

## 2.2.2 USB Wiring

This USB port is the standard USB A-type. A 50cm USB extension cord with installation plug is supplied with the controller. See sketch diagram picture 2-4 for reference.

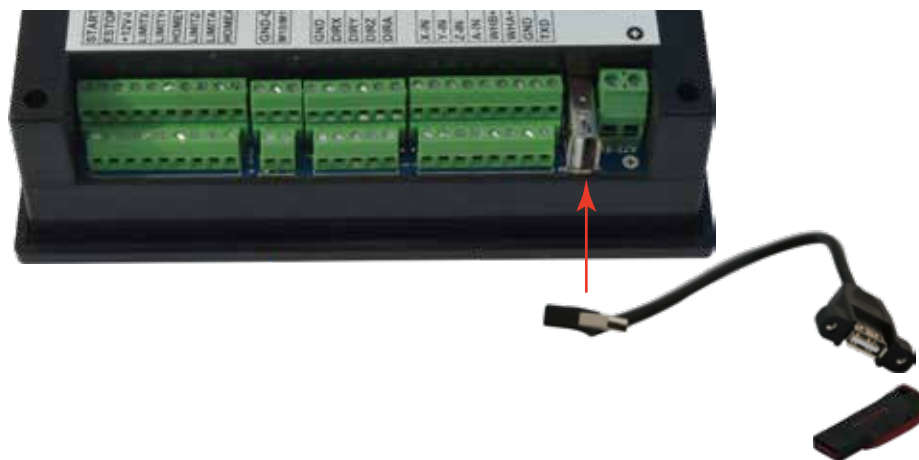

Picture 2-4 USB interface extension cord

## 2.2.3 MPG Port

The MPG port picture is shown in Picture 2-5. It is the 8+9 double row screw terminals next to the USB port.

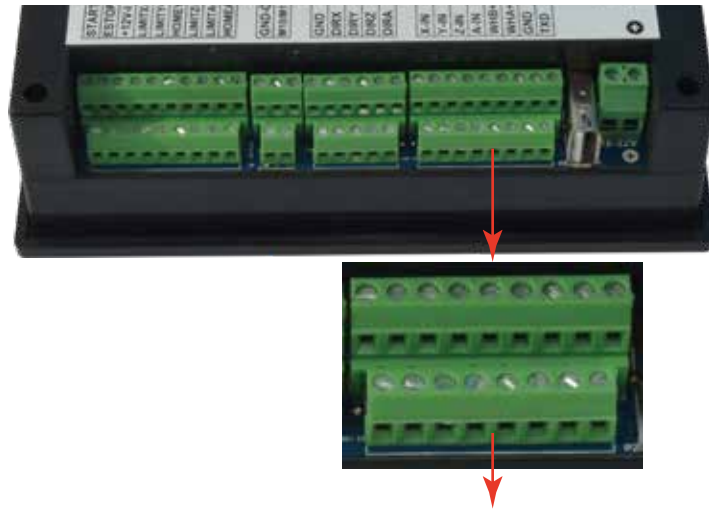

ESTOP	X1	X10	X100	GND	WHB-	WHA-	+5V-W	RXD
	X-IN	Y-IN	Z-IN	A-IN	WHB+	WHA+	GND	TXD

Picture 2-5 MPG port

The MPG port has 17 screw terminals, see Table 2-1 for reference. See Table 2-2 and table 2-3 for the wiring.

Pin Mark	Definition	Notes
ESTOP	ESTOP of MPG	Connect with GND,ESTOP is in effect.Open indicates Estop is invalid
X1	Select switch 1 X	Connect with GND, indicates selecting1 X, open indicates no pulse
X10	Select switch 10 X	Connect with GND, indicates selecting10 X, open indicates no pulse
X100	Select switch 100 X	Connect with GND, indicates selecting100 X, open indicates no pulse
Ground	MPG Ground	MPG power supply ground, so it is the switch signal reference ground
B phase-	MPG B phase negative	MPG B phase differential input negative terminal
A phase-	MPG A phase negative	MPG A phase differential input negative terminal
+5V-W	MPG power supply 5V output	Exclusive use supply terminal of MPG, which can restore the fuse connection with a 200MA of the system power supply.
RXD	MPG serial communication input	Used for digital display of theMPG communication
X select	Select switch of X axis	Connect with GND, indicates selecting X axis, open indicates no selecting
Y select	Select switch of Y axis	Connect with GND ,indicates selecting Y axis, open indicates no selecting
Z select	Select switch of Z axis	Connect with GND, indicates selecting Z axis, open indicates no selecting
A select	Select switch of A axis	Connect with GND, indicates selecting A axis, open indicates no selecting
B phase+	MPG B phase positive	MPG B differential input positive terminal
A phase+	MPG A phase positive	MPG A phase differential input positive terminal
ground	MPG ground	MPG power supply reference ground.
TXD	MPG serial communication output	Used for digital display of the MPG

Table 2-1 Cr8-500's MPG Port





DDCS V2.1 Wiring Pin	MPG Pin Mark and Color	
ESTOP	C	Light blue
X1	X1	Grey
X10	X10	Black/Grey
X100	X100	Orange
X Select	X	Yellow
Y Select	Y	Black/Yellow
Z Select	Z	Brown
A Select	4	Black/Brown
A phase+	A+	Green
A Phase-	A -	Purple
B phase+	B+	White
B Phase-	B-	Purple/Black
Ground	0V/CN/COM	Black;Black/Light Blue;Black/Orange
+5V-W	+5V	Red

Table 2-2 Differential MPG and DDCS V2.1 wiring mode

Note: It you want to use the single-terminal MPG (there is no A-B-MPG), please refer to table 2-3 for reference. As for the unlisted MPG, please take the differential MPG wiring mode.

DDCS V2.1 Wiring Pin Mark	MPG Pin Mark and Color	
A phase+	A+	Green
A phase-	0V	Black
B phase+	B+	White
B phase-	0V	Black

Table 2-3 Single-terminal MPG and DDCS V2.1 wiring modeh

## 2.2.4 Stepper/Servo control output

Picture 2-6 shows the stepper/servo control output screw terminals (second group of screw terminals from the right). As for the connection between system and stepper motor drive, please refer to Table 2-4.

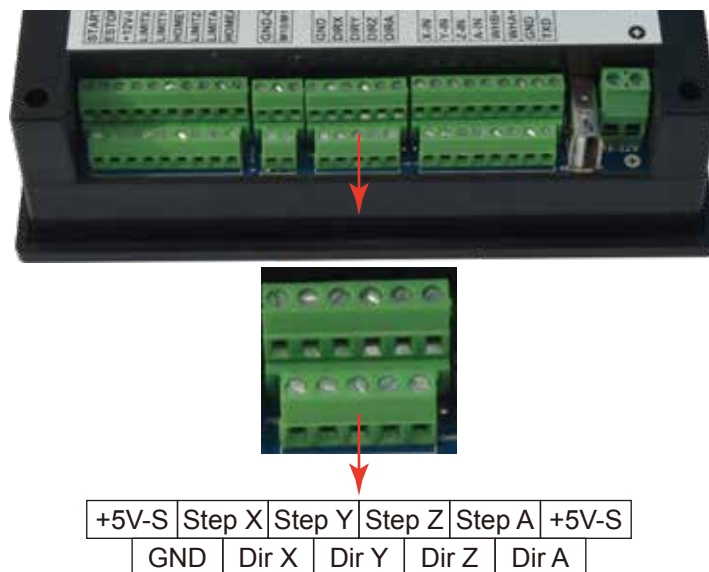

Picture 2-6 Stepper/servo control output terminal

Stepper/servo control interface wiring reference table 2-4

Pin Mark	Definition	Note: positive+common wiring method
+5V-S	5V+ positive terminal	Common terminal for Step+ and Dir+
Ground	GND Note: Strictly avoid to directly connect +5V to GND	Not used
Pulse X -	X axis pulse	X axis pulse signal negative terminal
Direction X-	X axis direction	X axis direction signal negative terminal
Pulse Y-	Y axis pulse	Y axis pulse signal negative terminal
Direction Y-	Y axis direction	Y axis direction signal negative terminal
Pulse Z-	Z axis pulse	Z axis pulse signal negative terminal
Direction Z-	Z axis direction	Z axis direction signal negative terminal
Pulse A-	A axis pulse	A axis pulse signal negative terminal
Direction A-	A axis direction	A axis direction signal negative terminal

Table 2-4 DDCS V2.1 stepper/servo control interface definition

## 2.2.5 Spindle control output

As the picture 2-7 shows, the third group of screw terminal blocks from the right are the spindle control output terminals. As for the definition, please see Table 2-5.

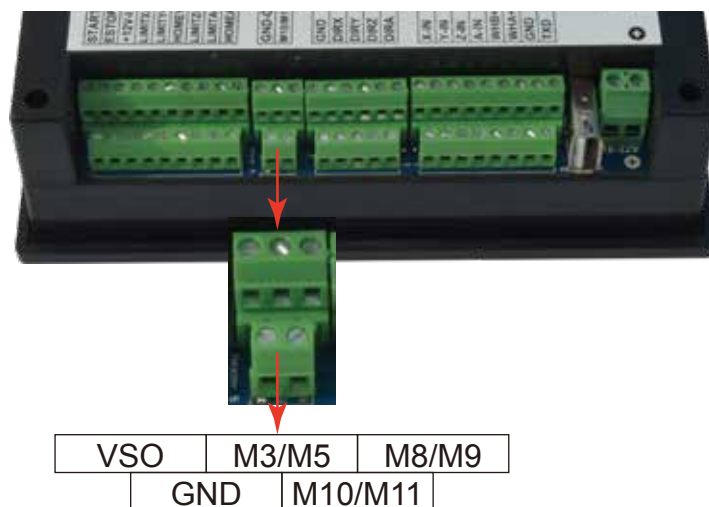

Picture 2-7 Spindle control output terminal

The spindle control output terminal offers connections for Start and Stop of the Spindle (M3/M5), Start/Stop of Cooling (M8/M9) and Start/Stop of Lubrication (M10/M11). These three output terminals are signals open to ground. The highest electric current can be absorbed is 50mA. The speed controlling output terminal can output 0-10V. It can adjust the speed of the spindle motor by sending the voltage between 0 and 10V to the VFD according to the Spindle Speed Setting.

Controlling the speed of a spindle with a VFD (variable frequency drive) only needs the Start/Stop signal and the 0-10V signal to control the frequency.

M3/M5 is connected to FWD (sometimes called FOD, Forward),

GND-0 is connected to CM (also called DCM),

VSO connects to Speed adjustment which defined by voltage 0-10V,

GND-0 connects to CM (also called ACM).

Many VFD's have DCM and ACM in common so only one needs to be connected. In case they are not in common, both need to be connected.



 DDCS V2.1 wiring pin	 SUNFAR E300
Speed output (0-10V) VSO	AI
Start and stop of spindle (open ground)	FWD
Output ground	CM
Output ground	Note: Some VFD's have the ground for 0-10V and the input signal FWD separate. In those cases both grounds need to be connected.

Table 2-5 DDCCS V2.1 VFD wiring

## 2.2.6 E-STOP, Limit, Home and Probe Inputs

As picture 2-8 shows, the far left terminal block is the Input Port. See pictures for reference

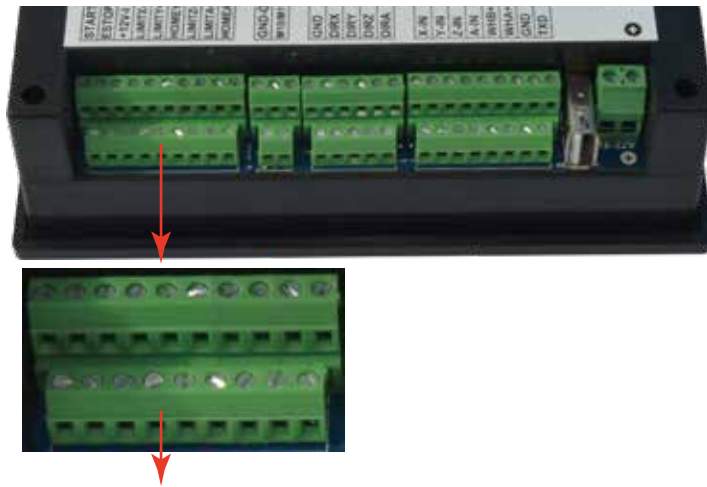

+12V	Pause	Probe	Limit X+	Home X	Limit Y-	Limit Z+	Home Z	Limit A-	GND
Start	Estop	+12V	Limit X-	Limit Y+	Home Y	Home Z-	Limit A+	Home A	

Picture 2-8 Input Port terminal

This screw terminal block contains three kinds of input signals. The external switches for Start and Pause, Probe, Limit/Home and E-Stop. Home and Limit switches can be NO or NC, the parameters can be set accordingly in the Parameter Page.

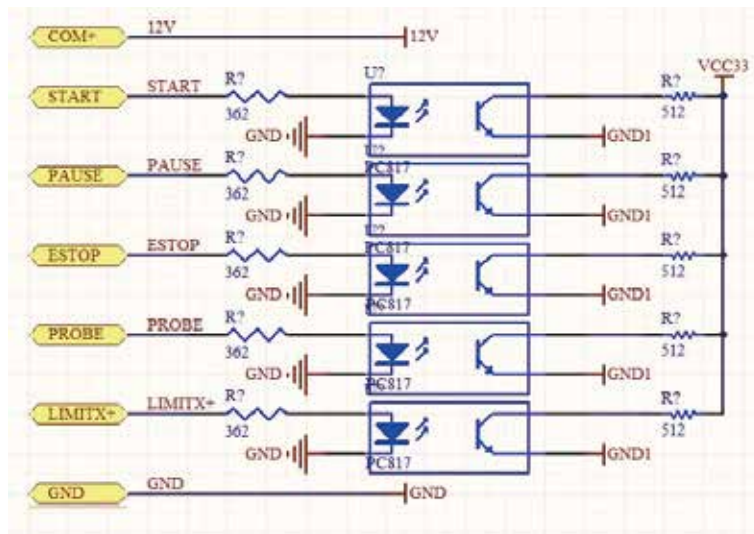

Picture 2-9 ESTOP, LIMIT and PROBE input signal circuit

The following picture 2-10 shows the wiring of the external Start, Pause and E-Stop

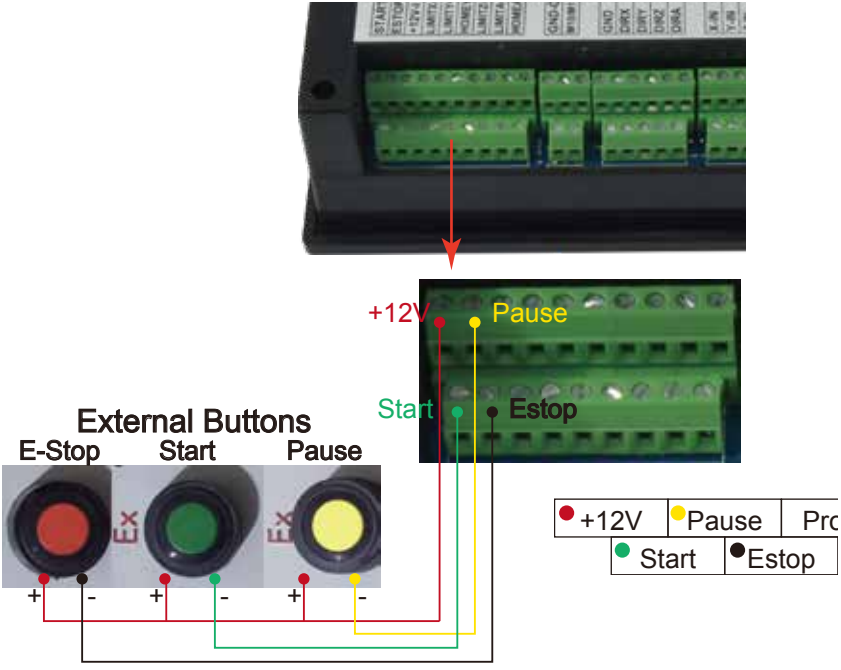

Picture 2-10 Wiring diagram of the external Start, Pause and ESTOP

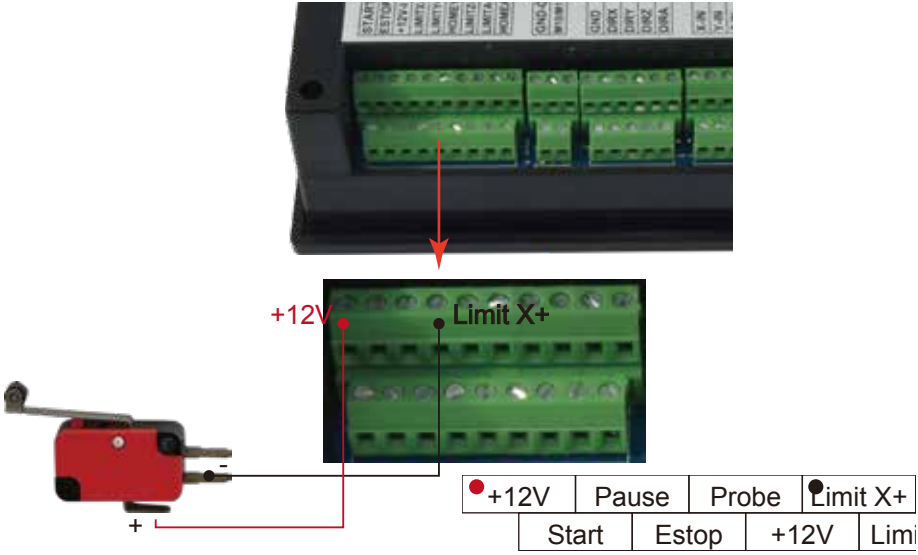

Picture 2-11 Wiring of Limit X+ switch

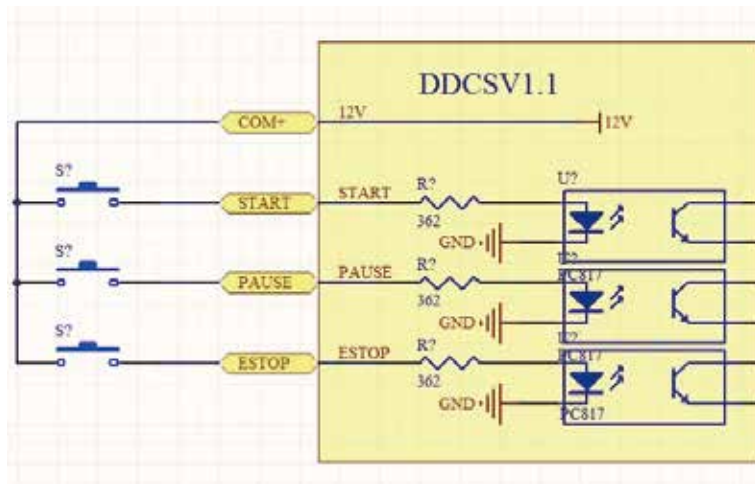

Picture 2-12 Wiring of Limit X+ switch

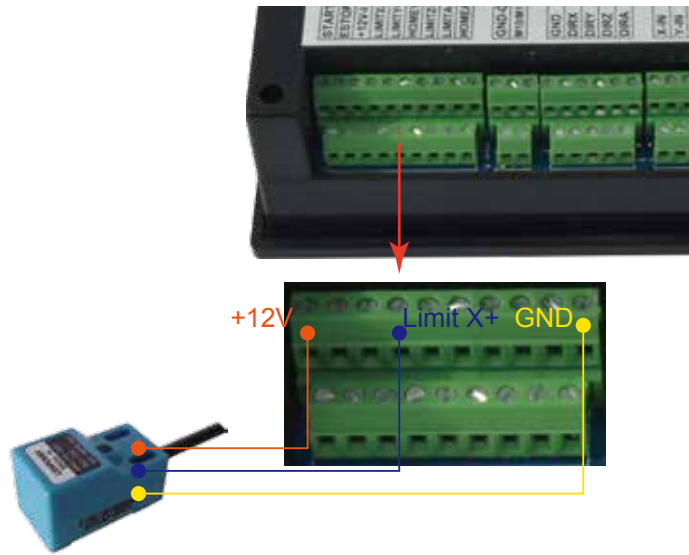

+12V	Pause	Probe	Limit X+	Home X	Limit Y-	Limit Z+	Home Z	Limit A-	GND
Start	Estop	+12V	Limit X-	Limit Y+	Home Y	Home Z-	Limit A+	Home A	

Picture 2-13 Wiring of Limit X+ switch

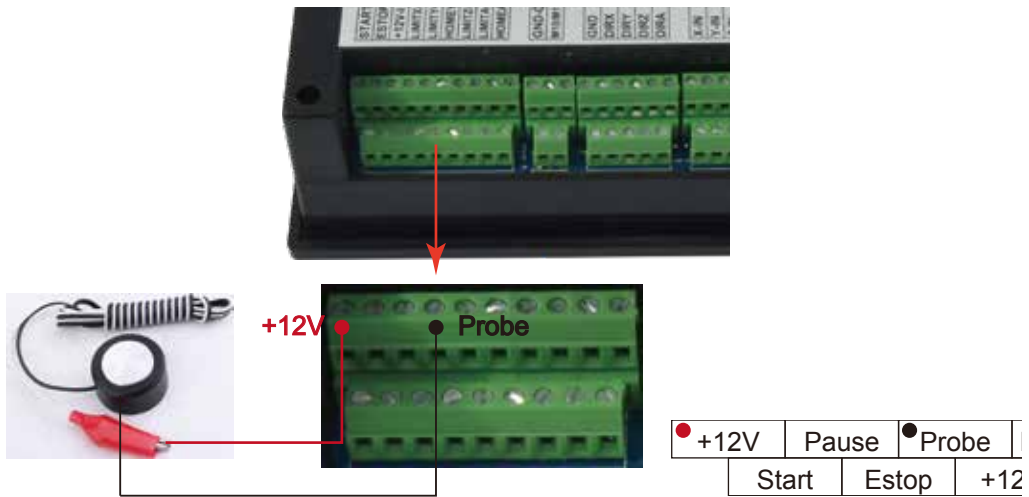

Picture 2-14 Wiring of the Probe

Limit/home general micro switch or wiring mode of 2-line Inductive proximity switch:



Picture 2-15 Inductive proximity switch wiring mode

# 3 Software Operation and Parameter Settings

## 3.1 Interface description

The software interface contains 3 pages. Main page, File page and Configuration page.

### 3.1.1 Main page

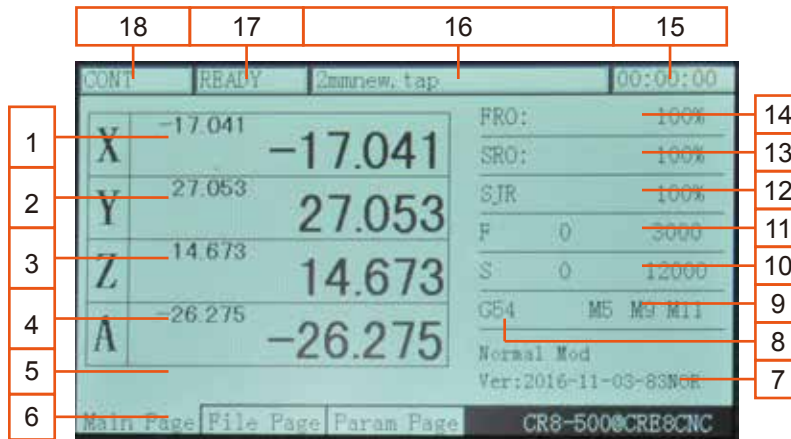

Picture 3-1 Main page

The picture 3-1 shows the Main page of the DDCS V2.1. It is divided into status column, coordinate display column, basic parameter column, and notification column. In total, it is divided into 18 sections in detail. Here the detailed description of the 18 sections :

#### 1、 X Coordinate

This column shows the current coordinate value of X. The display range is -99999.999~+99999.999, the minimum JOG value is 0.001.

#### 2、 Y Coordinate

This column shows the current coordinate value of Y. The display range is -99999.999~+99999.999, the minimum JOG value is 0.001.

#### 3、 Z Coordinate

This column shows the current coordinate value of Z. The display range is -99999.999~+99999.999, the minimum JOG value is 0.001.

#### 4、 A Coordinate (This section has no definition in the 3-axis)

This column shows the current coordinate value of A. The display range is -99999.999~+99999.999, the minimum JOG value is 0.001.

#### 5、 Current Operation

When the controller runs the G code file, it will show the current operation line number and coordinates. When the operation state is READY, it will show nothing

#### 6、 Page

The page shows the current page. This controller has 3 pages, Main Page, File Page and Configuration Page. Press Page button to move between the Pages.

#### 7、 Operation Window

This message window switches between 3 displays. It shows the prompt message of several keys and the 2nd (second function)



The message displayed while in normal state is: Normal Mode.

The message displayed of the 2nd function status is:

X-: goto, Y-: zero, Z-: home, A-: probe, Start: goto break

If you now click X-, the machine will move to Zero. If you click A-, the probe function will be activated. If you click Y-, all coordinates will be set to Zero. If you click Z-, the machine will home. If you click Start, the Start Line window appears and you can enter the G-code line you want to start from. Click on Pause to enter the breakpoint CONT Callback Function.

Tip:

You need to click these functions twice to activate them (first click is “select”, second click is “activate”).

Tip:

When you are in an Editing Window, you can insert values by using the following keys:

X-: moves the cursor left

X+: moves the cursor right

Y-: decrease the value

Y+: increases the value

Z-: Enter

Z+: Cancel

## 8 Coordinate System

With the DDCS V2.1 control panel it is very easy to control your Machine Coordinates and Work Offset Coordinates. Click FRO/SRO/SJR (from now on only called FRO) 6 times until the coordinate system is highlighted. Here you can display G54 to G59 and MACH (Machine Coordinates) by clicking A+ and A-

Tip

After selecting a function with the FRO key you use the A+ button to Select and the A- button to Modify the value.

If the function can be edited, the Editing Window will open and you can edit with:

X-: moves the cursor left

X+: moves the cursor right

Y-: decrease the value

Y+: increases the value

Z-: Enter

Z+: Cancel

## 9、 Status of M3/M5,M8/M9 or M10/M11

M3/M5: Start/Stop Spindle

M8/M9 : Start/Stop of Cooling

M10/M11: Start/Stop of Lubrication

## 10、 Speed of spindle

S stands for Spindle Speed. Click FRO till S is highlighted,click A- to modify and edit the value you want.

The display shows two values. The left value is the real time Spindle Speed, the right value shows the default Spindle Speed. The Default Spindle Speed can be changed, use the A- key to modify.

## 11、 Feed speed

F stands for Feed Speed. Click FRO till F is highlighted, click A- to modify and edit the value you want.

The display shows two values. The left value is the real time Feed Speed, the right value shows the default Feed Speed. The Default Feed Speed can be changed, use the A- key to modify and edit.

## 12、 SJR

SJR controls the jogging of the machine. Click FRO till SJR is highlighted.

First Option: MODE

Check window 18 and you can see what Jog Mode you are in. By clicking MODE you can change Jogging to Continuous, Step or to MPG, Window 18 will display this function.

When in Cont Mode, A+ and A- can adjust the speed in 10% increments

When in Step Mode, A+ and A- can change from 0.01mm to 0.1mm to 1mm and to 10mm

When in MPG mode you can use the MPG to jog the machine

Second Option: Jog a defined distance

## 13、 SRO

SRO controls the Spindle Speed. Click FRO till SRO is highlighted, use A+ and A\_ to adjust the Spindle Speed in 10% increments

## 14、 FRO

FRO controls the Feed Speed. Click FRO till FRO is highlighted. Use A+ and A- to adjust the Feed Speed in 10% increments

## 15、 Working time

This column shows the processing time of the G code operation. Time keeping is halted during Pause

## 16、 Processing file

This column shows the name of the processing files. In the formal situation, it only shows the filename. Under the situation of CONT adjust, it will also show the content of the file.

## 17、 Operating Status

This column shows the operating state. The status and implications can be displayed as follows:

Busy: Operation is running

Reset: Reset flashing = controller not active. To activate the controller click Reset

READY: Ready state. Controller is ready and all operations can be performed

## 18、 Feed status

This window shows the feed status of Jogging and File Processing.

AUTO: displayed while processing and executing the G code file

CONT: indicates Jog CONTINUOUS. You can Jog manually with the “-” or “+” keys of X Y Z and A. A short click will move the axis in the defined step, a long click will move the axis till you let go

Step: Jogging in Step Mode

### 3.1.2 File Management Page

Click the Page button once and the File Management Page will open

Name	Size	Time
.	[DIR]	1970/01/08 03:37
MCTEST	[DIR]	1970/01/08 03:37
plan	[DIR]	1970/01/08 03:37
install	[DIR]	1970/01/08 03:37
003.nc	109548576	2015/07/05 21:53
eng	17833	2016/12/16 14:00
Cre-500_SETTING_PAGE.xls	500758	2016/12/16 13:38

Picture 3-2 File management page

As the picture 3-2 shows, the file management page can be divided into 5 columns

- 1、 Change Directory
- 2、 Subfolder list of current Directory
- 3、 File list of current Directory
- 4、 Files size column Shows file size in byte
- 5、 Modification time and date

### 3.1.3 Configuration Page

Click the Page button once and the File Management Page will open:

No.	Param Name	Value	Unit
5	minimum log radius of 4axis machinir	5.000	mm
6	A axis rotate reference axis	X axis	
104	A axis optmal path when G0 run	No	
33	Motor start speed	50.000	mm/min
34	X axis pulse equivalency	640.000	pulse/mm
35	Y axis pulse equivalency	640.000	pulse/mm
36	Z axis pulse equivalency	640.000	pulse/mm
38	A axis pulse equivalency	640.000	
39	A axis pulse unit	pulse/deg	
40	AB axis Selection	A axis	
390	X axis DIR signal Electric Level	Low	

Picture 3-3 Configuration page

As the picture 3-3 shows, the configuration page can be divided into 4 columns:

1. Parameter Number

Each parameter has a specific number, the parameter can be modified .

2. Parameter Name

The definition of the Parameter is listed in the Parameter Name column. All Parameters are divided into groups according to their function.

### 3. Parameter Value

The Parameter Value column lists the value of each Parameter. This value can be configured

### 4. Parameter Unit

The Parameter Unit lists the unit of each parameter.

## 3.2 Definition of Keys

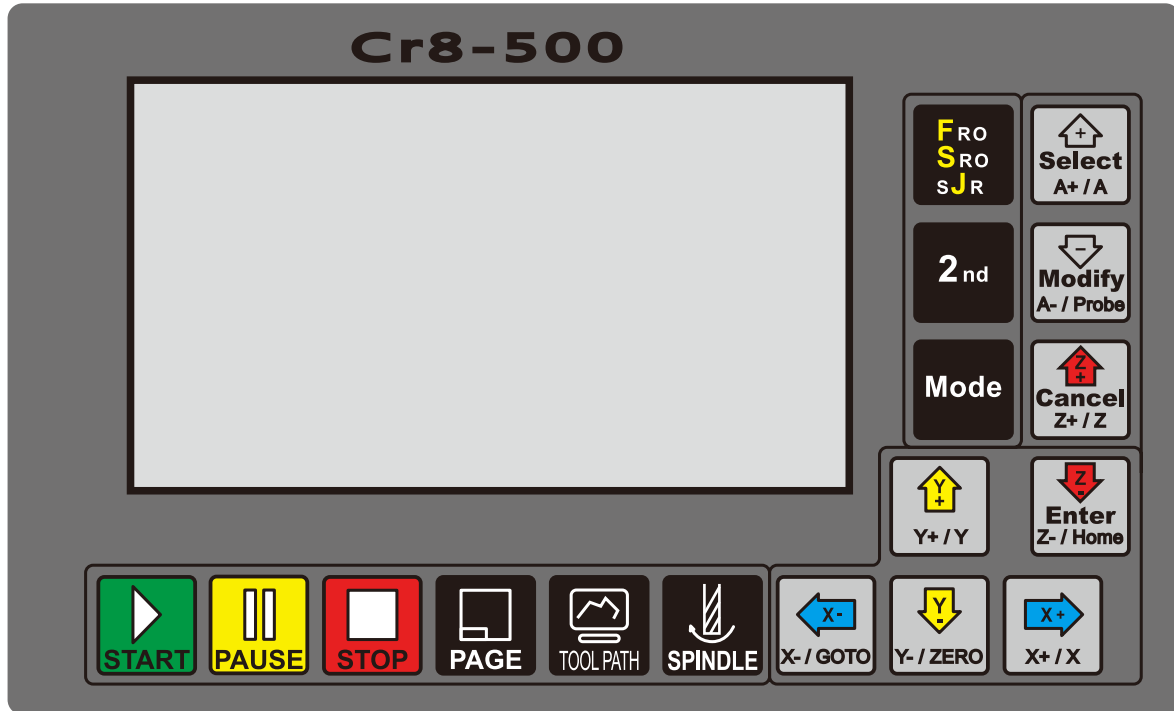

Picture 3-4 Keys Layout

The picture 3-4 shows the key layout of the DDCS V2.1. The Controller DDCS V2.1 has 17 keys. Please see table 3-1 for reference.

Keys Icon	Function No.	Definition	Notes
	1	Start operation	After loading the G code file, please press this key to start the operation. In case of Pause Status, press this key to continue the processing operation.
	1	Pause operation	Press this key to Pause the operation.
	1	Reset and E-STOP	If Reset is blinking, press this key to activate the controller. Press this key to stop processing urgently.
	1	Page switch	Switch through File Management Page, Processing Main Page and Parameter Configuration Page.
	1	Toolpath display switch	Switch the display between Coordinate Display or Tool Path Tracking display.
	1	Spindle manual start/close	Press this key to manually switch the spindle on or off. Can not be used if Reset is blinking and while processing an operation (Busy)















Keys Icon	Function No.	Definition	Notes
	3	1: X axis moves left; 2: Cursor moves left 3: Goto Zero function	In "CONT Mode", the X axis will Continuously move negative after pressing this key. In "STEP Mode" X will move negative in steps. When in "Line Editing" or default F/S value modification, this key moves the cursor left. When in "2nd Function", this key has the goto Zero function.
	3	1: X axis moves right; 2: Cursor moves right 3: X axis select	In "CONT Mode", the X axis will Continuously move positive after pressing this key. In "STEP Mode" X will move positive in steps. When in "Line Editing" or default F/S value modification, this key moves the cursor right. When in "home/zero-clearing/ gotoz", this key opens the X axis coordinate edit window.
	3	1: Y axis moves forward; 2: Parameter value increases 3: Y axis select	In "CONT Mode", the Y axis will continuously move positive after pressing this key. In "STEP Mode" Y will move positive in steps. When in "Line Editing" or default F/S value modification, this key increases the value. When in "home/zero-clearing/ gotoz", this key opens the Y axis coordinate edit window.
	3	1: Y axis move backward; 2: Parameter value decreases; 3: Start the current coordinate 0-clearing	In "CONT Mode", the Y axis will continuously move negative after pressing this key. In "STEP Mode" Y will move negative in steps. When in "Line Editing" or default F/S value modification, this key decreases the value. When you start the 2nd function, this key has the Ycoordinate function.
	3	1: Z axis Plummer block 2: Z axis select 3: cancel	In "CONT Mode", the Z axis will continuously move positive after pressing this key. In "STEP Mode" Z will move positive in steps. When in "home/zero-clearing/ gotoz", this key opens Z axis coordinate edit window. This key is also CANCEL key.
	3	1: Z axis down 2: home 3: enter/select	In "CONT Mode", the Z axis will continuously move negative after pressing this key. In "STEP Mode" Z will move negative in steps. This key serves as the ENTER key and also is the HOME key
	4	1: A axis rotates in forward direction 2: A axis select 3: parameter increases 4: F/S default select/cancel	In "CONT Mode", the A axis will continuously move positive after pressing this key. In "STEP Mode" A will move positive in steps. When in "home/zero-clearing/ gotoz", this key opens the A axis coordinate edit window. When in FRO/ SRO/ SJR this key increases the parameter value. When in F or S, this key switches between default value or G code value
	4	1: A axis rotates in inversion direction 2: Probefunction 3: Parameter decreases 4: F/S default modification	In "CONT Mode", the A axis will continuously move negative after pressing this key. In "STEP Mode" A will move negative in steps. When in 2nd function, this key activates the PROBE. When in FRO/ SRO/ SJR this key decreases the parameter value. When in F or S, this key will open the Editing Window
	2	1: FRO/SRO/SJR/F/S/G ; 2: file copy	This switch will highlight the processing parameters FRO/ SRO/SJR/F/S/G54-59-MACH/M3-M11 While in BUSY it can activate FRO and SRO In File Management this is the COPY key
	2	1: Second function start 2: file paste	This key will activate 2nd Mode (goto, zero, home, probe, goto breakpoint) . In File Management it is the PASTE key
	2	1: mod switch 2: file delete	When in READY, this key changes the Jog mode from Continuous to Step and MPG control. In File Management it is the DELETE key

Table 3-1 List of Keys' function

### 3.3 Operation of common functions

TIP

Do not press two keys at the same time

For example:  +  indicates that you should first press  and then release this key, then press 

#### 3.3.1 File Management

When in the Main Page press  to enter the File Page, See Picture 3-5

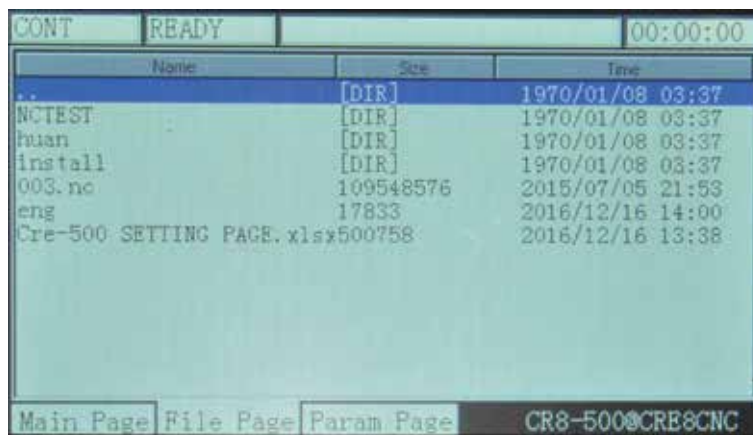



Picture 3-5 File management page

The displays will show all folders and files in the root directory. The Name of folders and files, the size of files and the time and date of manipulation. The blue strip indicates the current valid target location.

Press  to move up

Press  to move down

Press  to quit the file management page

Press  If the blue bar is at “ . . ”, the Enter button will change to the last directory. If the blue bar

highlights a folder, it will open the folder. If the blue bar highlights a G code file, this button will load the G code and go back to the Main Page for processing. If the blue bar highlights a .set file, it will upgrade the system. In this case make sure you delete the settings file or the upgrade will overwrite the original settings file too and you will lose your settings.

1) Copy the file

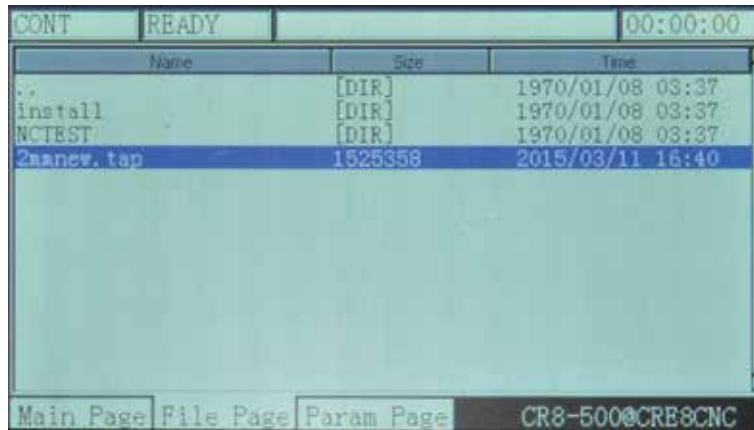

Picture 3-6 Select 2mmnew.tap file and copy the file

Here the 2mmnew.tap file is selected. Press the  key to copy the 2mmnew.tap file into memory

2) Paste the file

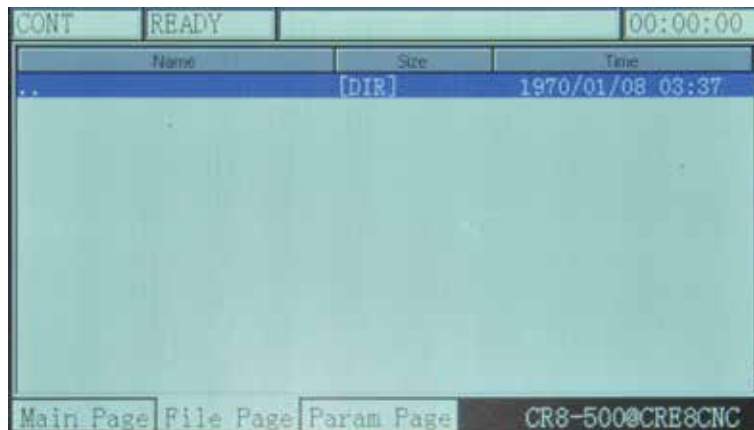

Picture 3-7 Switch to the target folder

Choose your target directory or target folder, click  to paste the 2mmnew.tap file to this directory. See picture 3-8 for reference

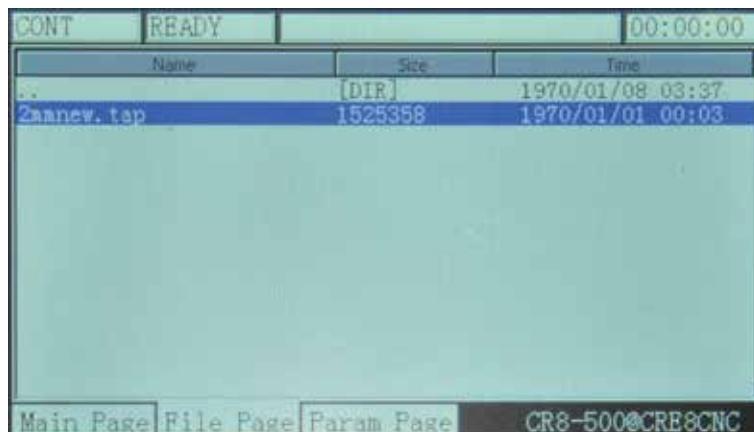

Picture 3-8 Paste the 2mmnew.tap file to this directory

### 3) Delete a file

Highlight the required file and click  to delete the file

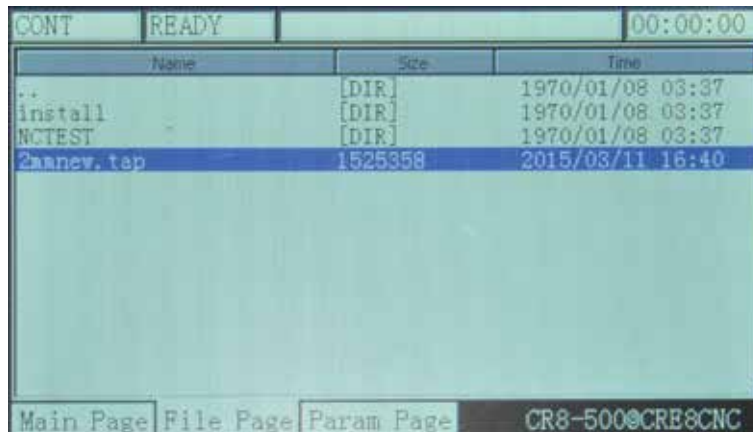

Picture 3-9 Move the blue strip to the 2mmnew.tap file, click MODE to delete

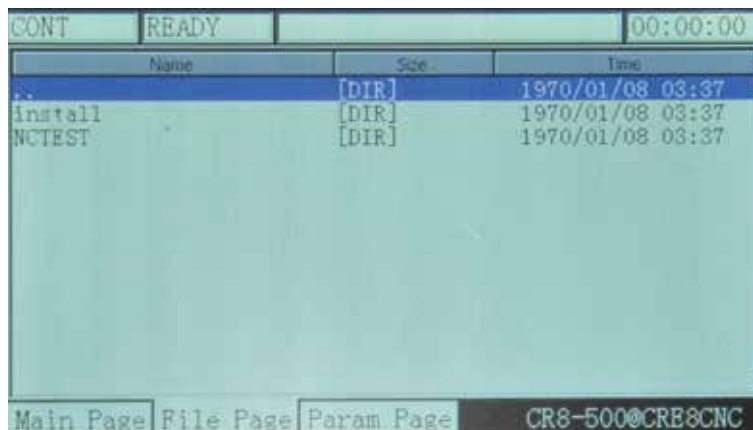

Picture 3-10 Delete the 2mmnew.tap file

### 4) Load the G code file

Highlight the G code file required and click . The file will be loaded and the screen will change back to the Main Screen for processing. The file name will be displayed.

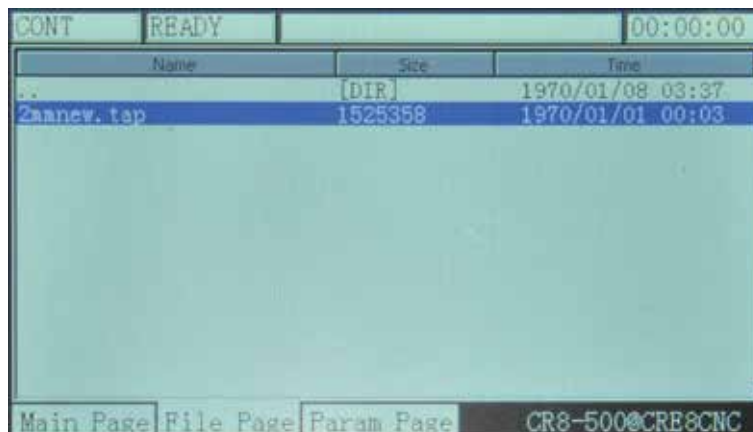

Picture 3-11 Search for the file 2mmnew.tap



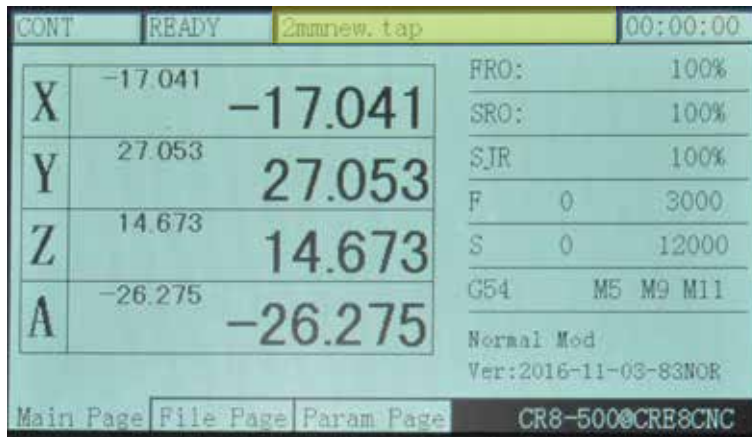

Picture 3-12 After loading the file 2mmnew.tap the file name will be displayed

### 3.3.2 Running a G code file

#### 1) Start running G code

After loading the G code file, make sure the controller is in READY. If RESET is blinking, just press the



key and ensure the operation status column displays READY.

Now set ZERO as requested. For example, if the G code file defines the work piece center as the XY ZERO point, move the cutter to that position.



Click the button and then click the Y- button. The Operation Window will give you several options. Click X+ and an EDIT WINDOW will open. Click ENTER to Zero X.



Click the button again and then click the Y- button. Now click X+ and an EDIT WINDOW will open. Click ENTER to Zero Y.



After ZERO is set, press the button to run the G code file. During Gcode processing, only the function



of , and are valid. The key can set the values of FRO (Processing Speed) and SRO (Spindle Speed).

See Picture 3-13.

Look at Current Operation (just below the Axis Read Out). It shows that the G code has been processed

to line 526<sup>th</sup>. The controller now is in BUSY Mode. Press the



to switch the display to show the tool path. Picture3-14,15 and 16 show the tool path display.



Picture 3-13 G code processing

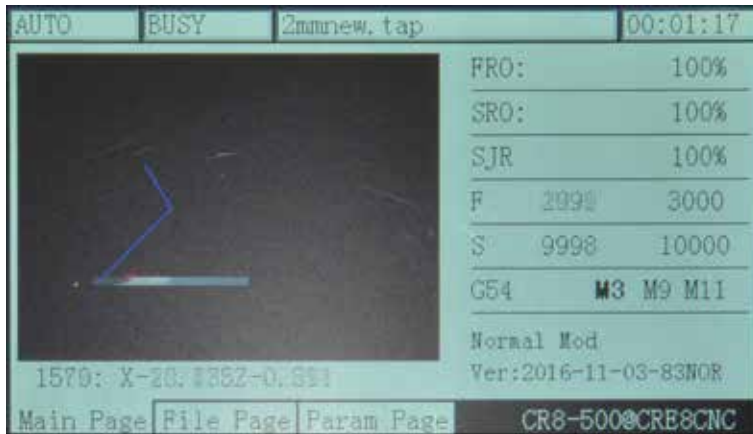

Picture 3-14 Tool path display after processing about half the file

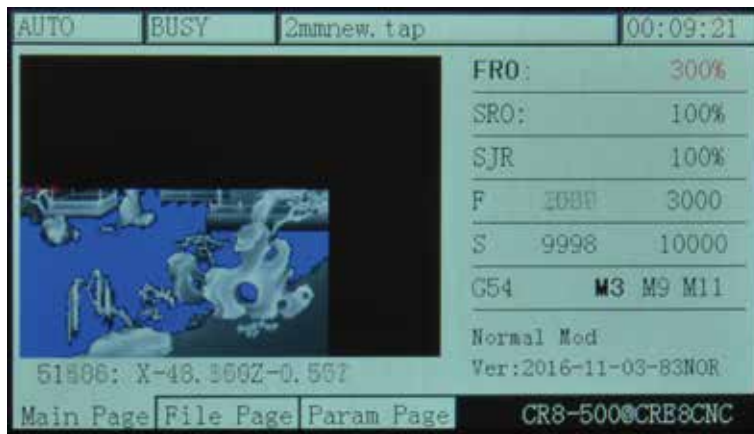

Picture 3-15 Tool path display after processing most of the file

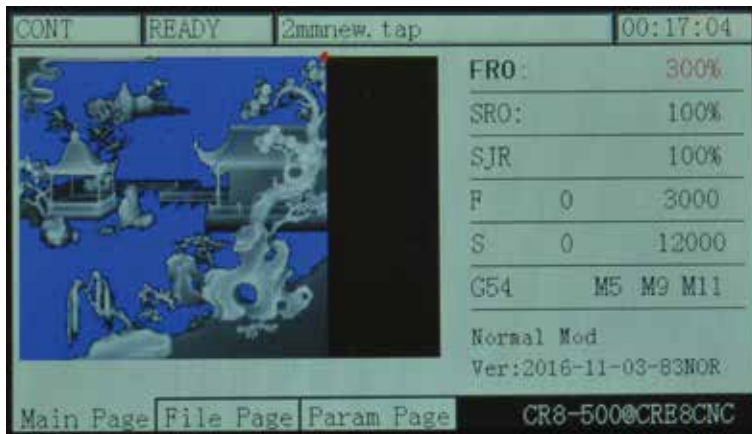

Picture 3-16 Tool path display, processing completed

## 2) Breakpoint operation

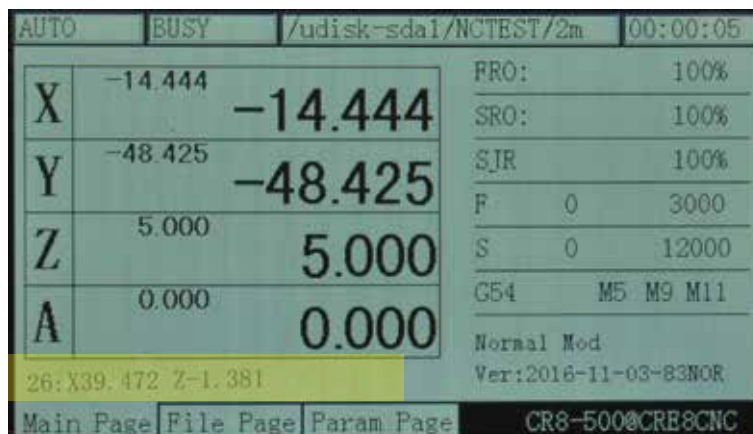

Press  to enter the 2nd mode. Click  to enter the breakpoint operation. The controller will run from the last record breakpoint.

Note: When you click , it will automatically produce a breakpoint. In case of power outage, it will also automatically record the breakpoint. As the picture 3-17 shows, it begins processing from the 26<sup>th</sup> line at this time. Picture 3-17 shows the display under the “goto break” status and the display shows the file name.



Picture 3-17 Breakpoint Operation

## 3) Start a G code file from a specific line

Click  to enter the 2nd mode. When in 2nd mode, click  and the Start Line Edit Box will appear. Insert the line number and click . A syntax check will be performed and the G code will be operated from your chosen Start Line position. See pictures 3-17 to 3-19.

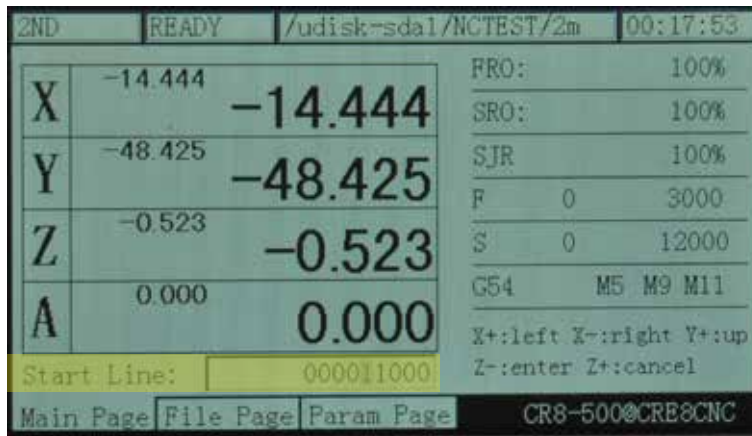

Picture 3-17 Edit the start line

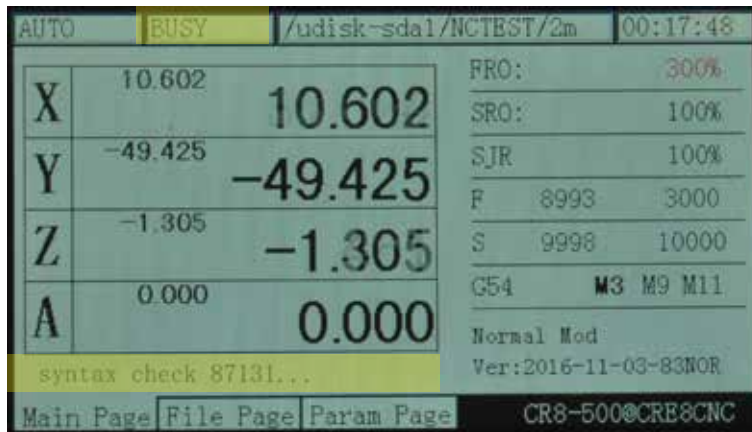

Picture 3-18 Syntax Checking

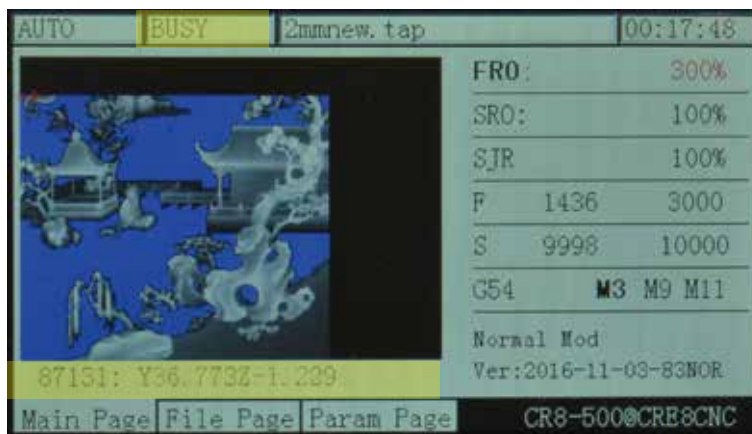

Picture 3-19 Program will run from the chosen line

#### 4) Pause in operation

During file processing, press the  key to pause the operation. The Operation Status Column will display “READY” and the Z axis will lift the tool to the defined safe height.

#### 5) ESTOP in operation

During file processing, press the  key to ESTOP the procedure. The Operation Status Column will display “RESET” flashing. The spindle will stop.

#### 6) Start/Stop spindle







Only when the Operation Status Column displays “READY” you can manually start or stop the spindle.

Use  the spindle button to switch from Start to Stop and back.



### 3.3.3 Manually position the machine

You can manually position the machine at any position. You can move Continuous, in defined Steps or with the MPG. The  button moves you through the three options

#### 1) Manual step of the X axis

Press  till “step” is displayed. In picture 3-22 Step parameter shows the current step rate (10mm).  
Press the  button till SJR is highlighted and you can change the steps by  and  keys.  
Press the  key to move the X axis negative 1mm, and press  to move the X axis 1mm positive.  
Move Y Z and A in the same way.

#### 2) Manual continuous operation of the X axis

Click  till CONT is displayed. The feed status displays “CONT”. See picture 3-22. You can now move the axis continuous with the arrow keys. Adjust the Jog speed by highlighting SJR and modify the jog speed with  and . All other axes can be moved in the same way.

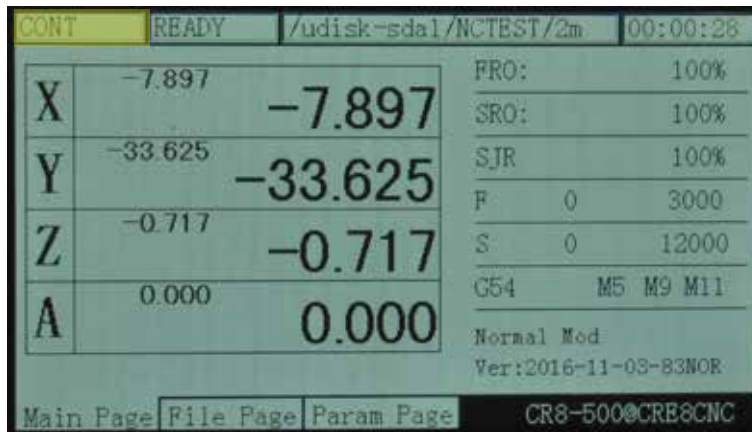

Picture 3-20 Enter the manual Continuously moving mode

### 3) Use MPG to operate X axis

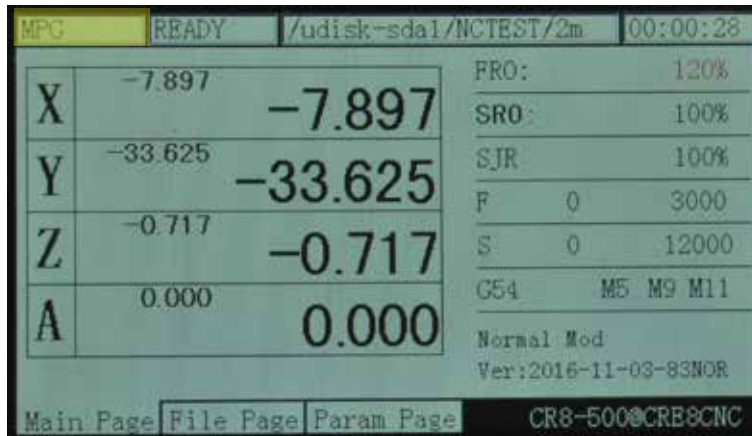

Click  till the Feed Status displays “MPG”. Use the MPG to move the machine.



Picture 3-21 Enter the MPG mode



## 3.3.4 Main Page Parameter adjustments

The values FRO, SRO, SRJ, F, S Coordinate system and the M codes can easily be changed



Click  till the display highlights what you want to adjust and then click  or .

### 1) FRO

The FRO parameters. Under “READY” press  till FRO is highlighted (bold).

With  and  adjust the value between 0% to 300%

### 2) SRO

The Spindle adjustment controls the spindle’s speed. Highlight SRO and use  and  to adjust the spindle speed from 0% to 200%

### 3) SJR

The SJR is to adjust the jog speed. In “CONT” mode you can adjust from 0% to 150%.



In “Step” mode you can adjust 0.01mm, 0.1mm, 1mm and 10mm. Use **Modify A-/Probe** and **Select A+/A** to adjust and choose your value. Click on the Axes arrow keys will move the machine this distance once.

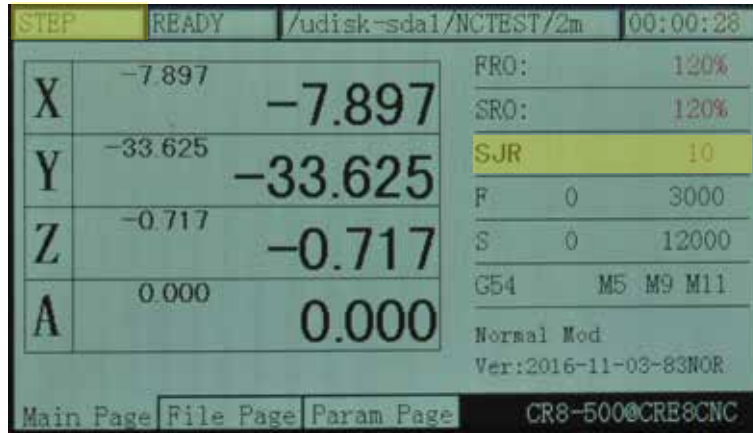

Picture 3-22 SJR value adjusts to 10 under the mode of “step”

### 4) F Value modification



The F value adjustment the default Feed Speed. Use the **FRO SRO SJR** key to highlight F.

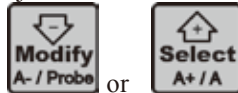

If you click **Modify A-/Probe** or **Select A+/A** an Edit Window will appear Choose your desired Feed speed and confirm with Enter. See picture 3-23

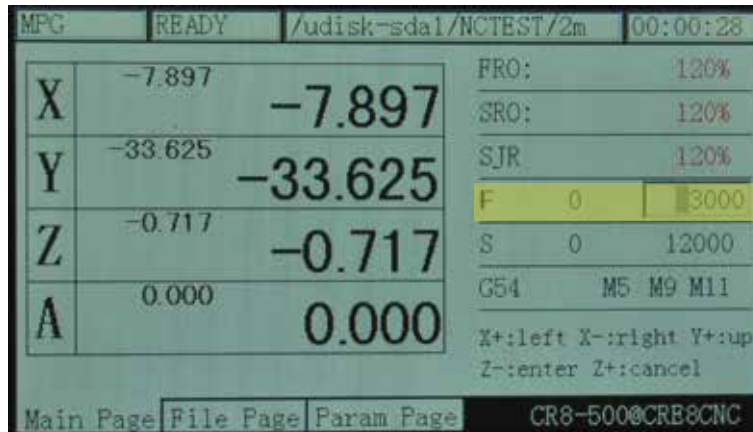

Picture 3-23 Enter default F modification mode

5) S Value modification

Use the  key to highlight S. If you click  or  an Edit Window will appear

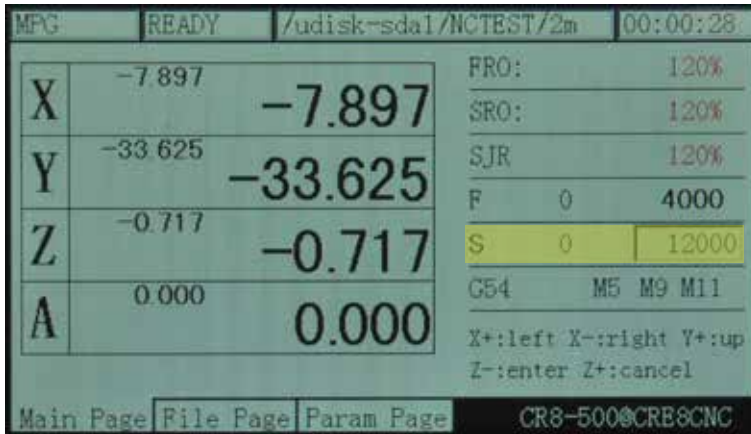

Choose your desired Feed speed and confirm with Enter.



Picture 3-24 Enter the status of modifying default S value

6) Select G coordinate system

Under “READY”, press the  key till the Coordinate System is highlighted. It will display G54, ....G59 or MACH (stands for Machine Coordinates).

Use  and  to choose your desired Coordinate System. Position values will be displayed for X, Y, Z and A. The Enter key confirms the Coordinate System you chose.



### 3.3.5 The 2nd Mode

The 2nd key opens several functions.

In READY mode, the Operation Window displays “Normal Mode”. Press **2<sup>nd</sup>** to enter the 2nd mode. The Operation Window will show: X-:gotoz Y-:zero Z-: home A-:probe start:goto break and the Feed Status column displays “2nd mode”. See picture 3-25. You can now make your choice which may open new options accordingly.

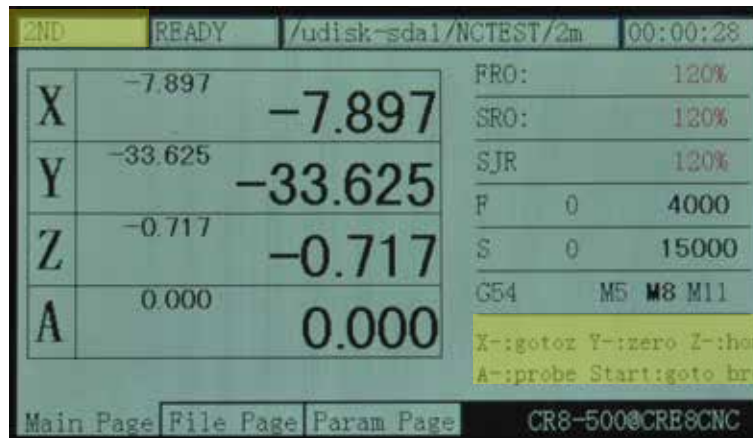

Picture 3-25 Enter the “2nd function” Mode

Tip

Lets say you want to choose the center of your material as the X and Y Zero position. Move the machine with the arrow keys to the desired XY position. Alternative use the MPG to do this.

Now press the **2<sup>nd</sup>** key and the Operation Window will show: X-:gotoz, Y-:zero, Z-: home, A-:probe, start:goto break .

Press the **2<sup>nd</sup>** key again and the coordinates of X Y and Z will show 0.000

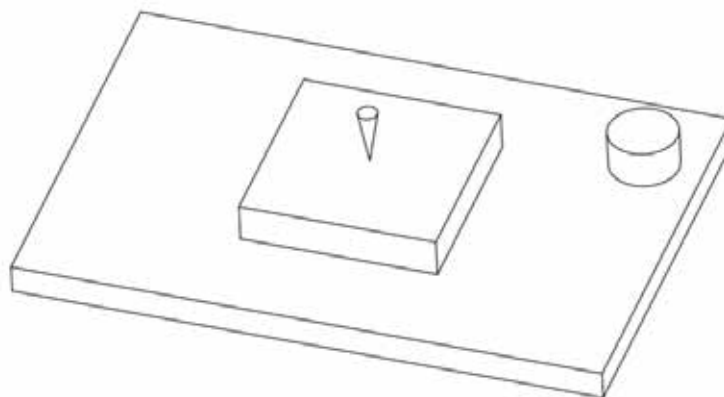

Picture 3-26 The tool tip over the work piece center

Tip:

Do not forget to probe again after a tool change

### 3.4 Parameter setting

The DDCS V2.1 stores the machine settings in a parameter file called setting.set. This file is a basic text file. You can modify all the parameters in the Parameter Page but also within the setting.set file. Originally the DDCS V2.1 will be loaded with the default setting and you can change the settings in the Parameter Page (or in the text file setting.set) to adjust for your machine.

Tip:

Back up your setting.set file... just in case.

#### 3.4.1 Parameter loading method

Copy the parameter file to the USB drive and insert it into the USB interface on the controller. As the

Picture 3-27 shows, press the key  in the main page to ensure that the status column can display

“READY” and then press the key  to switch to the file management page. As the Picture 3-28 shows,

select the parameter file Uservar.set and then press the Enter key  to load the parameter file. It probably needs to wait for 1-5s and the “READY” of status column will automatically change into “reset” with flashing, which indicates the parameter loads successfully.

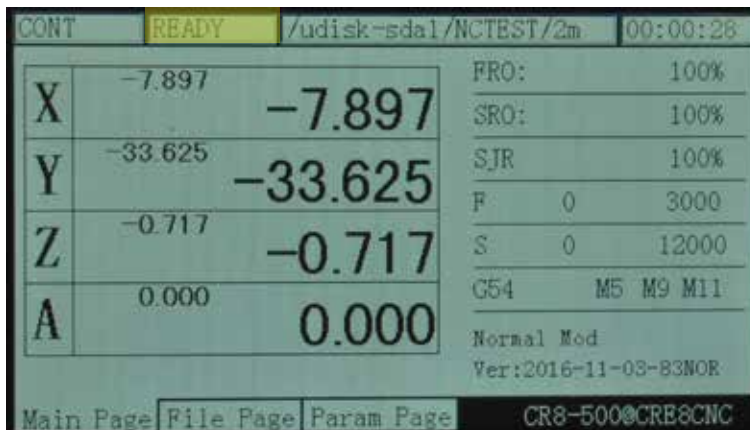



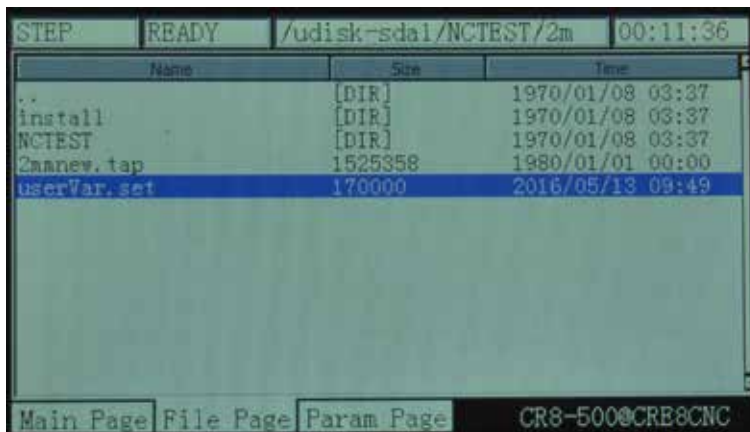









Picture 3-27 Ensure the status column is the status of “READY”



Picture 3-28 Select the uservar.set file and enter

### 3.4.2 Set the Parameters in the Parameter setting Page

In the main page, ensure the operation status is “READY” and press the key  two times continuously to enter the Parameter Page. As the picture 3-29 shows, in the parameter configuration page, pressing the key  and  is to turn the page forward and backward. Pressing the key  and  is to select the current parameter items up and down. When you select the parameters which are required to modify, please press the key  to enter the current parameter modification mode. At this time, it will pop up a small dialog box of the modified value, which is the same with the other parameters. Pressing the key  and  is to adjust the current bit. Pressing the key  and  is to adjust the value of the current bit. After finishing modification, please press the key  to return to the parameter select. After finishing modifying the parameter, it needs to press  to return to the homepage, thus loading the parameter and making the parameter takes effect.

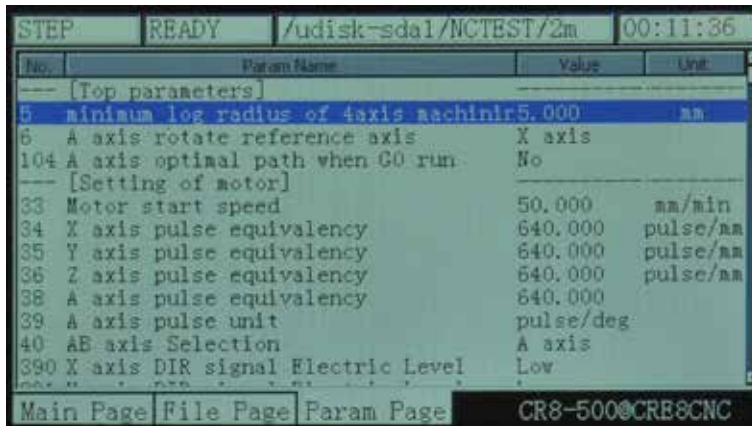

Picture 3-29 Enter the parameter configuration page

### 3.4.3 The detailed definition of parameters

The parameter file can be edited, but it needs to follow the definite standards, the standards are as follows:

- a、 One line can only be edited one parameter.
- b、 The parameter format is #parameter mark= value. Among them, # must be the first character of each line.# should closely be followed by the parameter mar and the following mark is=, and the make= will be followed by the actual value.
- c、 After the parameter has assignment and equation, the part of parameter interpretation can have any format without constraint.
- d、 Each parameter is regulated with assignment scope. Please do the assignment in strict accordance with the assignment scope.
- e、 Each parameter is set with default value in advance. Please use the setting value of default parameter under the situation of not understanding the actual function of this parameter.

1) Configuration parameter of motor (16 in total)

Para. Mark	Parameter definition	Default value	Parameter Unit	Parameter Scope	Notes
#33	speed of motor start running	50	mm/min	0~200	Speed of motor start running's first step
#34	Pulse /mm X axis	640	Pulse/mm	100~10000	
#35	Pulse /mm Y axis	640	Pulse/mm	100~10000	
#36	Pulse /mm Z axis	640	Pulse/mm	100~10000	
#38	Pulse /mm A axis	640	Pulse/degree	100~10000	
#390	level of X axis DIR signal	0	BOOL	1/0	1=high,0=low
#391	level of Y axis DIR signal	0	BOOL	1/0	
#392	level of Z axis DIR signal	1	BOOL	1/0	
#393	level of A axis DIR signal	0	BOOL	1/0	
#416	time between DIR & pulse	300	ns	0~1000	Differential between direction and pulse
#418	level of X axis pulse signal	0	BOOL	1/0	axis pulse signal of X,Y,Z,A as well as the Pulse signal value when there is no pulse.
#419	level of Y axis pulse signal	0	BOOL	1/0	
#420	level of Z axis pulse signal	1	BOOL	1/0	
#421	level of A axis pulse signal	1	BOOL	1/0	

2) Parameter of manual control motion(16 in total)

Para. Mark	Parameter definition	Default value	Parameter Unit	Parameter Scope	Notes
#41	max speed of X in M_Ctrl mode	16000	mm/min	0~20000	The parameter value of this group has set a upper limit for the SJR
#42	max speed of Y in M_Ctrl mode	16000	mm/min	0~20000	
#43	max speed of Z in M_Ctrl mode	16000	mm/min	0~20000	
#44	max speed of A in M_Ctrl mode	16000	degree/min	0~20000	
#45	start Acceleration of X in M_Ctrl mode	600	mm/s <sup>2</sup>	0~2000	4 axis of X,Y,Z,A manual start acceleration
#46	start Acceleration of Y in M_Ctrl mode	600	mm/s <sup>2</sup>	0~2000	
#47	start Acceleration of Z in M_Ctrl mode	600	mm/s <sup>2</sup>	0~2000	
#48	start Acceleration of A in M_Ctrl mode	600	degree/s <sup>2</sup>	0~2000	
#100	manual control speed of X axis	8000	mm/min	0~20000	Panel keys operation the X,Y,Z,A axis Continuously move speed
#101	manual control speed of Y axis	8000	mm/min	0~20000	
#102	manual control speed of Z axis	4000	mm/min	0~20000	
#103	manual control speed of A axis	12000	degree/min	0~20000	
#263	stop Acceleration of X in M_Ctrl mode	1200	mm/s <sup>2</sup>	0~2000	4 axis of X,Y,Z,A manually stop acceleration, the stop acceleration can be set appropriately larger
#264	stop Acceleration of Y in M_Ctrl mode	1200	mm/s <sup>2</sup>	0~2000	
#265	stop Acceleration of Z in M_Ctrl mode	1200	mm/s <sup>2</sup>	0~2000	
#266	stop Acceleration of A in M_Ctrl mode	1200	degree/s <sup>2</sup>	0~2000	

3) Automatic processing parameter(11 in total)

Para. Mark	Parameter definition	Default value	Parameter Unit	Parameter Scope	Notes
#15	Speed selection for Gcode file	1	BOOL	1/0	0:set by G code; 1:use default speed
#76	Default operation speed	1500	mm/min	0~20000	
#77	Max operation speed	8000	mm/min	0~30000	
#78	Max speed of Z+	3000	mm/min	0~20000	
#79	Max speed of Z-	3000	mm/min	0~20000	
#80	Speed of G0	5000	mm/min	0~20000	
#82	Safe height of Z axis	5	mm	0~500	Retract height of Z
#89	Z retract distance	5	mm	0~99	This value cannot be negative value
#99	Operation acceleration	500	mm/min <sup>2</sup>	0~2000	
#435	Max speed of X axis	8000	mm/min	0~20000	
#436	Max speed of Y axis	8000	mm/min	0~20000	

4) Parameter of coordinate system(1 in total)

Para. Mark	Parameter definition	Default value	Parameter Unit	Parameter Scope	Notes
#16	Current coordinate system	1	BOOL	0~6	0~5: G54~G59, 6: Machine

5) Parameter of spindle(8 in total)

Para. Mark	Parameter definition	Default value	Parameter Unit	Parameter Scope	Notes
#98	Max spindle speed	24000	rpm	0~50000	Spindle PWM or voltage signal full range is corresponding to speed value
#220	Spindle speed selection	1	BOOL	1/0	0: G code, 1: Default
#221	Default spindle speed	12000	rpm	0~50000	
#222	Activate M3/M5	1	BOOL	1/0	1: Yes; 0: No
#224	Delay time of M3/M5	3	s	0~100	Spare enough time for spindle response
#227	active level of spindle	1	BOOL	1/0	Corresponding output electrical level when the spindle starting
#422	definition of PWM level	0	BOOL	1/0	The output voltage value is 0, the spindle is 0, voltage is 10V, speed is full.
#433	Acceleration time of PWM	1111	Time equivalent	1~65535	The acceleration time to full speed is #433*0.0005s

6) IO output parameter(5 in total)

Para. Mark	Parameter definition	Default value	Parameter Unit	Parameter Scope	Notes
#223	Activate M code (M8/M9, M10/M11)	1	BOOL	1/0	1: Yes; 0: No
#225	Delay time of M8/M9	1	S	1~20	Delay time after M8/M9/M10/M11 code
#226	Delay time of M10/M11	1	S	1~20	
#228	Active level of M8/M9	1	BOOL	1/0	1: Yes; 0: No
#229	Active level of M10/M11	1	BOOL	1/0	1: Yes; 0: No

7) 0-point function parameter(20 in total)

Para. Mark	Parameter definition	Default value	Parameter Unit	Parameter Scope	Notes
#52	Enable X home	1	BOOL	1/0	1: Yes; 0: No
#53	Enable Y home	1	BOOL	1/0	
#54	Enable of Z home	1	BOOL	1/0	
#55	Enable of A home	1	BOOL	1/0	
#56	Home speed of X	8000	mm/s	1~20000	
#57	Home speed of Y	8000	mm/s	1~20000	
#58	Home speed of Z	8000	mm/s	1~20000	
#59	Home speed of A	8000	mm/s	1~20000	
#60	Signal Level X Home	0	BOOL	1/0	1: High; 0: Low
#61	Signal Level Y Home	0	BOOL	1/0	
#62	Signal Level Z Home	0	BOOL	1/0	
#63	Signal Level A Home	0	BOOL	1/0	
#64	direction of X home	0	BOOL	1/0	0: reverse direction home(--) 1: forward direction home(++)
#65	direction of Y home	0	BOOL	1/0	
#66	direction of Z home	0	BOOL	1/0	
#67	direction of A home	0	BOOL	1/0	
#83	back off distance of X after home	10	mm	0~1000	After homing, each axis needs to move away from the home switch for a certain distance. The parameter of this group is this back off distance
#84	back off distance of Y after home	10	mm	0~1000	
#85	back off distance of Z after home	10	mm	0~1000	
#86	back off distance of A after home	10	mm	0~1000	

8) Parameter of Probe function (8 in total)

Para. Mark	Parameter definition	Default value	Parameter Unit	Parameter Scope	Notes
#68	enable Probe	1	BOOL	1/0	0: disable 1: enable
#69	thickness of tool sensor	20	mm	0~200	
#70	level of probe signal	0	BOOL	1/0	1: High; 0:Low active
#71	initial tool's position	0	BOOL	1/0	0: current position; 1:fixed position mode
#72	initial X axis in fixed mode	0	mm	0-9999	Tools position X coordinate in the Mach(ine) coordinate system
#73	initial Y axis in fixed mode	0	mm	0-9999	Tools position Y coordinate in the Mach(ine) coordinate system
#74	initial Z axis in fixed mode	0	mm	0-9999	Height of Z axis before the XY move under the Mach(ine) coordinate system
#75	Back off distance after probing	10	mm	0~200	

9) Parameter of hard limit function(16 in total)

Para. Mark	Parameter definition	Default value	Parameter Unit	Parameter Scope	Notes
#400	enable X-- limit	1	BOOL	1/0	0: Disable 1: Enable
#401	enable Y-- limit	1	BOOL	1/0	0: Disable 1: Enable
#402	Enable Z-- limit	1	BOOL	1/0	0: Disable 1: Enable
#403	enable A-- limit	1	BOOL	1/0	0: Disable 1: Enable
#404	enable X++ limit	1	BOOL	1/0	0: Disable 1: Enable
#405	enable Y++ limit	1	BOOL	1/0	0: Disable 1: Enable
#406	enable Z++ limit	1	BOOL	1/0	0: Disable 1: Enable
#407	enable A++ limit	1	BOOL	1/0	0: Disable 1: Enable
#408	active level X-- limit	0	BOOL	1/0	1: High; 0:Low
#409	active level Y-- limit	0	BOOL	1/0	1: High; 0:Low
#410	active level Z-- limit	0	BOOL	1/0	1: High; 0:Low
#411	active level A-- limit	0	BOOL	1/0	1: High; 0:Low
#412	active level X++ limit	0	BOOL	1/0	1: High; 0:Low
#413	active level Y++ limit	0	BOOL	1/0	1: High; 0:Low
#414	active level Z++ limit	0	BOOL	1/0	1: High; 0:Low
#415	active level A++ limit	0	BOOL	1/0	1: High; 0:Low

10) Parameter of soft limit function (9 in total)

Para. Mark	Parameter definition	Default value	Parameter Unit	Parameter Scope	Notes
#374	enable Soft Limit	0	BOOL	1/0	0:Disable, 1:Enable
#375	value X-- Soft Limit	-400	BOOL	-2000~0	The set value will trigger the limit signal. The limit values refer to the machine coordinates, not the work piece coordinate.
#376	value Y-- Soft Limit	-400	BOOL	-2000~0	
#377	value Z-- Soft Limit	-400	BOOL	-2000~0	
#378	value A-- Soft Limit	-400	BOOL	-2000~0	
#379	value X++ Soft Limit	400	BOOL	0~2000	The set value will trigger the limit signal. The limit values refer to the machine coordinates, not the work piece coordinate.
#380	value Y++ Soft Limit	400	BOOL	0~2000	
#381	value Z++ Soft Limit	400	BOOL	0~2000	
#382	value A++ Soft Limit	400	BOOL	0~2000	

11) Parameter of MPG function(5 in total)

Para. Mark	Parameter definition	Default value	Parameter Unit	Parameter Scope	Notes
#428	Enable MPG RESET	1	BOOL	1/0	0: Disable,1: Enable
#429	Level of MPG RESET	0	BOOL	1/0	1: High; 0:Low
#430	Type of MPG port	1	BOOL	1/0	0:UART,1: Standard
#431	Pulse of MPG	0	BOOL	1/0	0: 100 steps /cycle,1: 24 steps /cycle
#432	IO signal level of MPG	0	BOOL	1/0	1: High; 0:Low

12) Parameter extended functions (7 in total)

Para. Mark	Parameter definition	Default value	Parameter Unit	Parameter Scope	Notes
#423	External RESET	1	BOOL	1/0	1: High; 0:Low
#424	Level External RESET	0	BOOL	1/0	1: High; 0:Low
#425	Enable of External Key	1	BOOL	1/0	0: Disable,1: Enable
#426	Level of External Key 1	0	BOOL	1/0	1: High; 0:Low
#427	Level of External Key 2	0	BOOL	1/0	1: High; 0:Low
#446	Function of External Key 1	0	BOOL	1/0	0:Start,1:Find Center
#447	Function of External Key 2	0	BOOL	1/0	0:Pause,1: Zero

13) Parameter of Backlash (9 in total)

Para. Mark	Parameter definition	Default value	Parameter Unit	Parameter Scope	Notes
#437	Enable of X backlash	0	BOOL	1/0	0:Disable,1:Enable
#438	Enable of Y backlash	0	BOOL	1/0	
#439	Enable of Z backlash	0	BOOL	1/0	
#440	Enable of A backlash	0	BOOL	1/0	
#441	Distance of X axis backlash	0	mm	0~200	Set the backlash return as you need for each axis. Tip: experiment with the settings and check the results
#442	Distance of Y axis backlash	0	mm	0~200	
#443	Distance of Z axis backlash	0	mm	0~200	
#444	Distance of A axis backlash	0	mm	0~200	
#445	Speed of backlash	0	mm/min	0~2000	

14 ) Other parameters(6 in total)

Para. Mark	Parameter definition	Default value	Parameter Unit	Parameter Scope	Notes
#1	Language	1	BOOL	1/0	0: English,1: Chinese
#2	Interface response speed while processing	400		400-10000	Note: For general G-code file, the parameter can be set as 400. If the file has many small segments, adjust the parameter to be larger.
#495	circle of interpolation	0.002	s	0.002-0.01	circle of interpolation
#250	enable of draw tool road	1	BOOL	1/0	0:disable 1: enable
#253	mode of draw	0	BOOL	1/0	0:statue mode 1:line mode
#499	user access key	888888	N/A	0-999999	

Mode of deaw tool road: As for the plane line, such as the PCB engraving or the color plates lettering, please adopt the line pattern. As for the plane embossment, please adopt the statue pattern.

### 3.5 Firmware upgrade

Decompress the upgrade file into the USB flash disk



Picture 3-30 Firmware patch upgrade , the numbers refers to the version

After you upgrade the firmware, the version number will appear in the Operation Window (7, lower right corner of the interface).

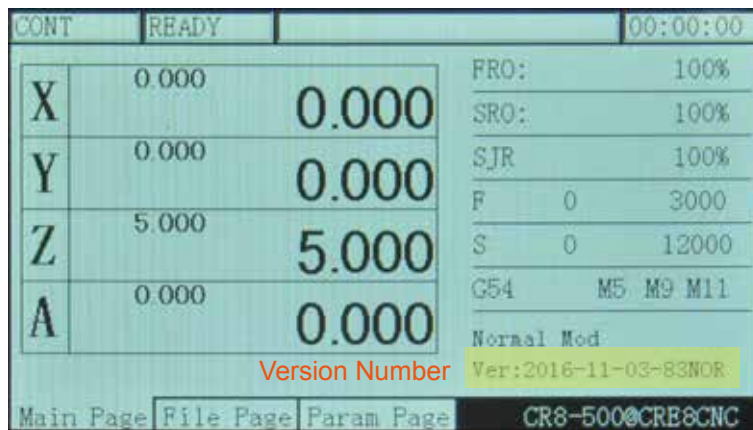

Picture 3-31 Upgrade file and its directory

Decompress the downloaded file onto a USB disk, direct into the root directory (not inside a folder). The file after decompressing will look like in picture 3-32

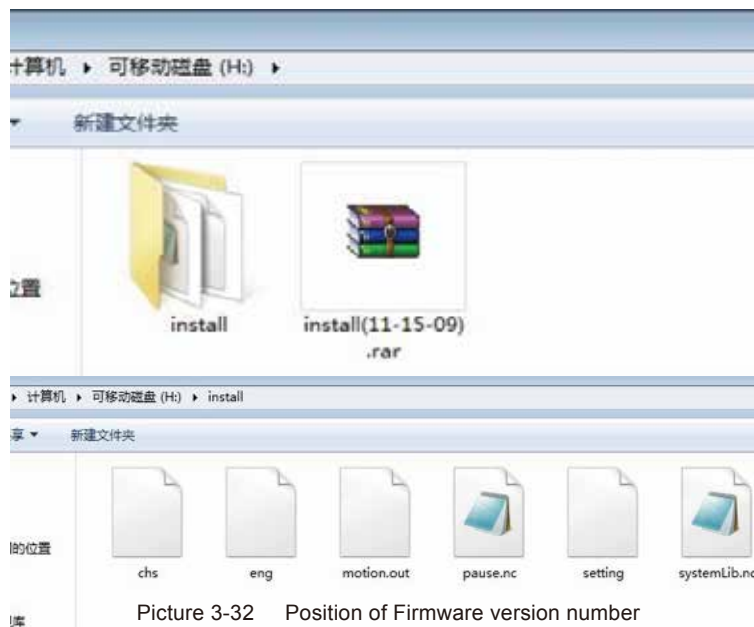

Picture 3-32 Position of Firmware version number



As the picture 3-33 shows, after decompressing the file into the USB's root directory, the file path is X://INSTALL/. The upgrade files are in this folder, it total 6 files. There is ch (Chinese) and eng (English). Motion.out is the main program. The pause.nc and systemLib.nc are the extended code files. Setting is the setting file.

**Important**

When upgrading, the entire configuration will be replaced. If you need to keep your Settings, delete the setting.set file in the install folder. Your original Settings will then not be changed.

The install folder must appear as in pic 3-32 or it can not be upgraded. If the folder name is not correct (for example install instead of install), the upgrade can not be performed. See as picture 3-33 and 3-34.

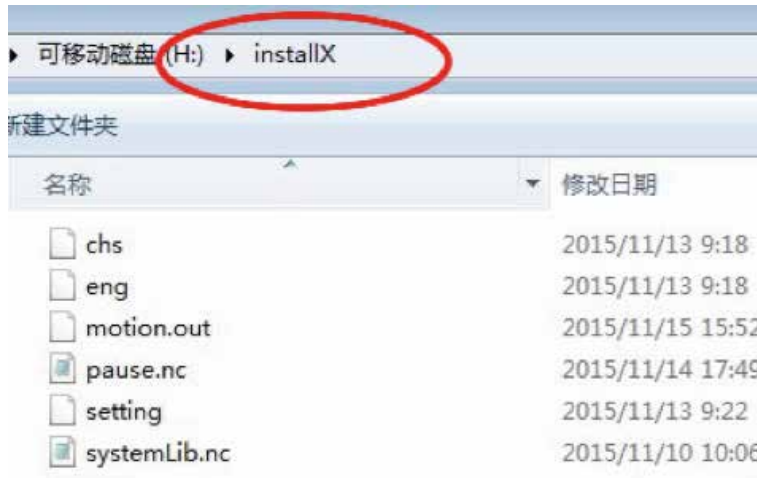

Picture 3-33 If the folder name is not correct, installation can not be performed.

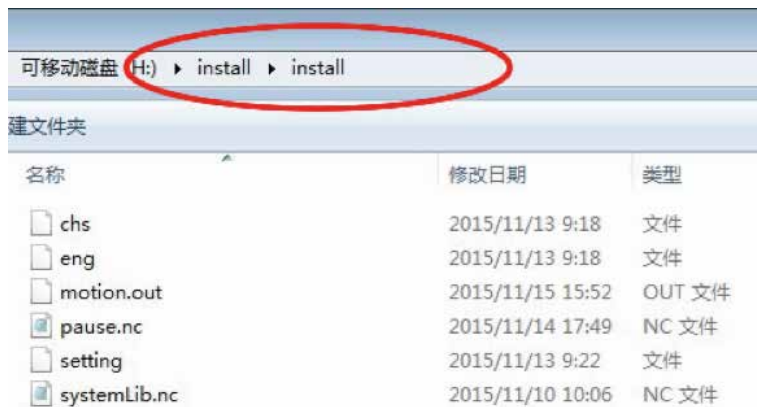

Picture 3-34 Multilevel directory can not work

**Begin to upgrade when USB is inserted into the equipment**

After you copied the install file to the USB key, insert the USB into the controllers USB port and then supply power to the controller. The update will be performed automatically and the screen will not change for about 30 seconds. Please be patient.

# CRE8CNC

## DDCS V2.1

500KHz 4 Axis CNC Controller

Picture 3-35 Screen displayed during upgrade process (approx 30 seconds)

The screenshot shows a CNC control interface with a dark background and light text. At the top, it displays 'STEP', 'READY', the file path '/udisk-sda1/NCTEST/2m', and the time '00:11:36'. Below this is a table of axis positions and parameters. The axes are X, Y, Z, and A. The X-axis position is 10.000, Y is 46.742, Z is -34.548, and A is 0.000. To the right of the axis positions are parameters: PRO: 100%, SRO: 100%, SJR: 0.1, F: 0 4000, S: 0 15000, G54 M5 M9 M11, Normal Mod, and Ver: 2016-12-25-16NOR. At the bottom, there are navigation buttons for 'Main Page', 'File Page', and 'Param Page', and the text 'CR8-500@CRE8CNC'. A red arrow points to the 'Ver: 2016-12-25-16NOR' text.

STEP	READY	/udisk-sda1/NCTEST/2m	00:11:36
X	10.000	10.000	PRO: 100%
Y	13.117	46.742	SRO: 100%
Z	-35.266	-34.548	SJR 0.1
A	0.000	0.000	F 0 4000
			S 0 15000
			G54 M5 M9 M11
			Normal Mod
			Ver: 2016-12-25-16NOR

Main Page File Page Param Page CR8-500@CRE8CNC

Picture 3-36 After the upgrade finished, the main page will be displayed. Check the version number

After the upgrade, the DDCS V2.1 can be used right away.